



Resistance and Capacitance Meter Using a PIC16C622

<i>Author: Rodger Richey Microchip Technology Inc.</i>
--

INTRODUCTION

The PIC16C62X devices create a new branch in Microchip's PIC16CXXX 8-bit microcontroller family by incorporating two analog comparators and a variable voltage reference on-chip. The comparators feature programmable input multiplexing from device inputs and an internal voltage reference. The internal voltage reference has two ranges, each capable of 16 distinct voltage levels. Typical applications such as appliance controllers or low-power remote sensors can now be implemented using fewer external components thus reducing cost and power consumption. The 18-pin SOIC or 20-pin SSOP packages are ideal for designs having size constraints.

The PIC16C62X family includes some familiar PIC16CXXX features such as:

- 8-bit timer/counter with 8-bit prescaler
- PORTB interrupt on change
- 13 I/O pins
- Program and Data Memory

Device	Program Memory	Data Memory
PIC16C620	512 x 14	80 x 8
PIC16C621	1K x 14	80 x 8
PIC16C622	2K x 14	128 x 8

This family of devices also introduce on-chip brown-out reset circuitry and a filter on the reset input (\overline{MCLR}) to the PIC16CXXX mid-range microcontrollers. Brown-out Reset holds the device in reset while V_{DD} is below the Brown-out Reset voltage of $4.0V, \pm 0.2V$. The reset filter is used to filter out glitches on the \overline{MCLR} pin.

This application note will describe:

- Comparator module
 - operation
 - initialization
 - outputs
- Voltage Reference module
 - operation
 - initialization
 - outputs
- Linear slope integrating Analog to Digital conversion techniques
 - advantages
 - disadvantages
- Overview of the application circuit
- Detailed description of the measurement techniques used in the application circuit

AN611

COMPARATOR MODULE

The comparator module contains two analog comparators with eight modes of operation. The inputs to the comparators are multiplexed with the RA0 through RA3 pins. The on-chip voltage reference can

also be selected as an input to the comparators. The Comparator Control Register (CMCON) controls the operation of the comparator and contains the comparator output bits. Figure 1 shows the CMCON register.

FIGURE 1: CMCON REGISTER

R-0	R-0	U-0	U-0	R/W-0	R/W-0	R/W-0	R/W-0
C2OUT	C1OUT	—	—	CIS	CM2	CM1	CM0
bit7				bit0			
<p>bit 7: C2OUT: Comparator 2 output 1 = C2 VIN+ > C2 VIN- 0 = C2 VIN+ < C2 VIN-</p> <p>bit 6: C1OUT: Comparator 1 output 1 = C1 VIN+ > C1 VIN- 0 = C1 VIN+ < C1 VIN-</p> <p>bit 5-4: Unimplemented: Read as '0'</p> <p>bit 3: CIS: Comparator Input Switch When CM2:CM0 = 001: 1 = C1 VIN- connects to RA3 0 = C1 VIN- connects to RA0 When CM2:CM0 = 010: 1 = C1 VIN- connects to RA3 C2 VIN- connects to RA2 0 = C1 VIN- connects to RA0 C2 VIN- connects to RA1</p> <p>bit 2-0: CM2:CM0: Comparator mode.</p>							

R = Readable bit
 W = Writable bit
 U = Unimplemented bit, read as '0'
 - n = Value at POR reset

A single comparator is shown in Figure 2. The relationship between the inputs and the output is also shown. When the voltage at V_{IN+} is less than the voltage at V_{IN-} , the output of the comparator is at a digital low level. When the voltage at V_{IN+} is greater than the voltage at V_{IN-} , the output of the comparator is at a digital high level. The shaded areas of the comparator output waveform represent the uncertainty due to input offsets and response time.

FIGURE 2: SINGLE COMPARATOR

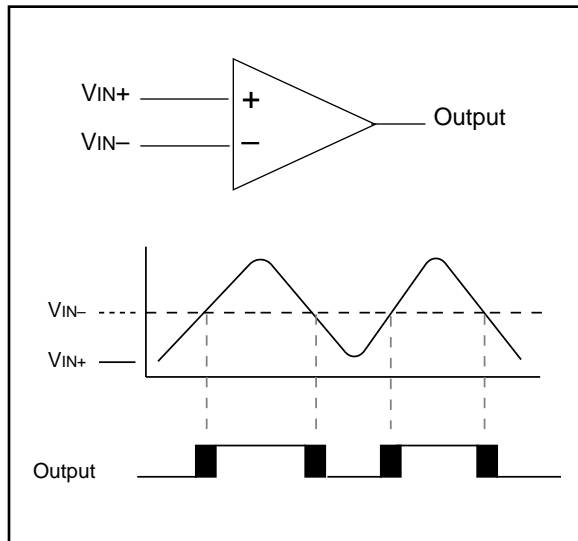

The TRISA register controls the I/O direction of the PORTA pins regardless of the comparator mode. If the comparator mode configures a pin as an analog input and the TRISA register configures that pin as an output, the contents of the PORTA data latch are placed on the pin. The value at the pin, which can be a digital high or low voltage, then becomes the input signal to the comparators. This technique is useful to check the functionality of the application circuit and the comparator module.

Comparator Operating Modes

The analog inputs to the comparator module must be between V_{SS} and V_{DD} and one input must be in the Common Mode Range (CMR). The CMR is defined as $V_{DD}-1.5$ volt to V_{SS} . The output of a comparator will default to a high level if both inputs are outside of the CMR. If the input voltage deviates above V_{DD} or below V_{SS} by more than 0.6 volt, the microcontroller may draw excessive current. A maximum source impedance to the comparators of 10 k Ω is recommended. Figure 3 through Figure 10 show the eight modes of operation.

FIGURE 3: COMPARATORS RESET

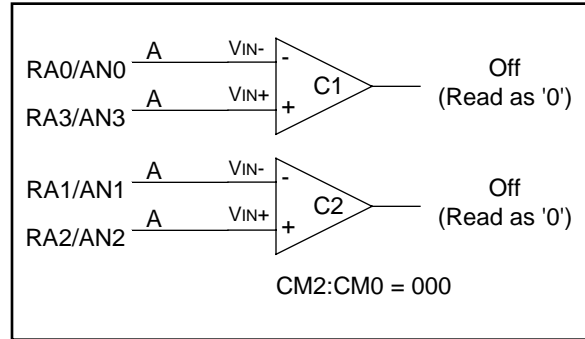

The Comparators Reset Mode (Figure 3) is considered the lowest power mode because the comparators are turned off and RA0 through RA3 are analog inputs. The comparator module defaults to this mode on Power-on Reset.

FIGURE 4: COMPARATORS OFF

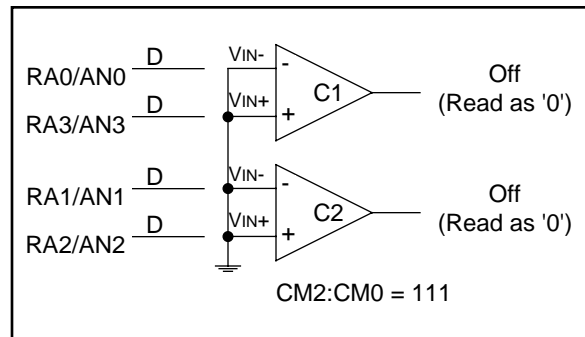

The Comparators Off Mode (Figure 4) is the same as the Comparators Reset Mode except that RA0 through RA3 are digital I/O. This mode may consume more current if RA0 through RA3 are configured as inputs and the pins are left floating.

FIGURE 5: TWO INDEPENDENT COMPARATORS

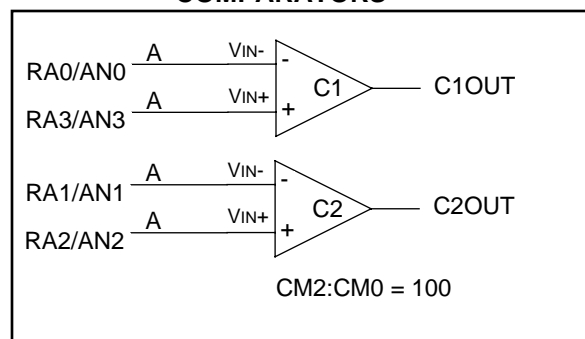

The Two Independent Comparators Mode (Figure 5) enables both comparators to operate independently.

AN611

FIGURE 6: FOUR INPUTS MULTIPLEXED TO TWO COMPARATORS

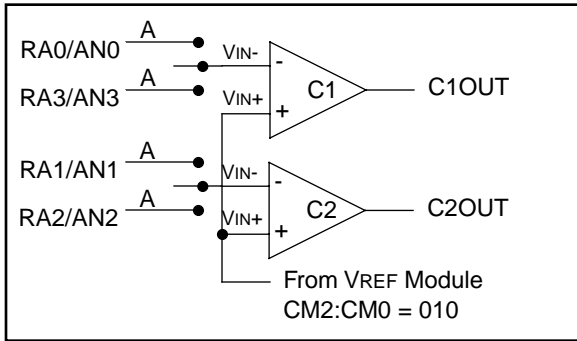

The Four Inputs Multiplexed to Two Comparators Mode (Figure 6) allows two inputs into the V_{IN-} pin of each comparator. The internal voltage reference is connected to the V_{IN+} pin of each comparator. The CIS bit, $CMCON\langle 3 \rangle$, controls the input multiplexing to the V_{IN-} pin of each comparator. Table 1 shows this relationship.

TABLE 1: COMPARATOR INPUT MULTIPLEXING

CIS	C1 V_{IN-}	C2 V_{IN-}
0	RA0	RA1
1	RA3	RA2

FIGURE 7: TWO COMMON REFERENCE COMPARATORS

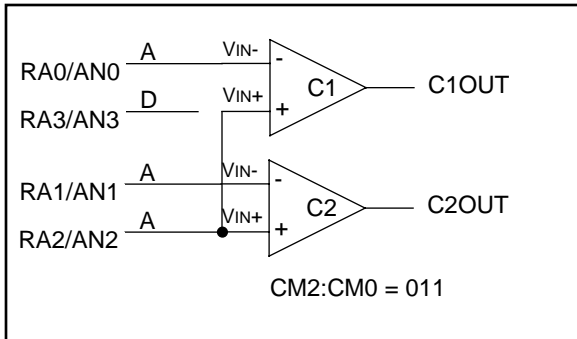

The Two Common Reference Comparators Mode (Figure 7) configures the comparators such that the signal present on RA2 is connected to the V_{IN+} pin of each comparator. RA3 is configured as a digital I/O pin.

FIGURE 8: TWO COMMON REFERENCE COMPARATORS WITH OUTPUTS

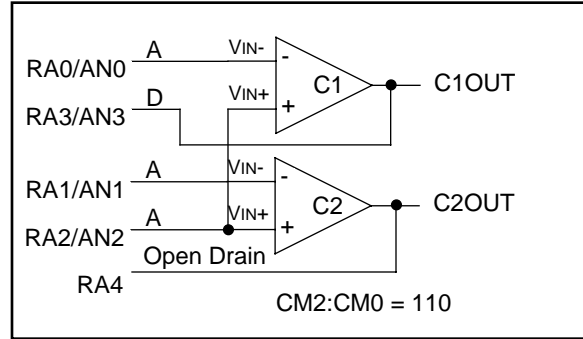

The Two Common Reference Comparators with Outputs Mode (Figure 8) connects the outputs of the comparators to an I/O pin. These outputs are digital outputs only with RA3 defined as a CMOS output and RA4 defined as an open drain output. RA4 requires a pull-up resistor to function properly. The value of resistance used for the pull-up will affect the response time of comparator C2. The signal present on RA2 is connected to the V_{IN+} pin of both comparators.

FIGURE 9: ONE INDEPENDENT COMPARATOR

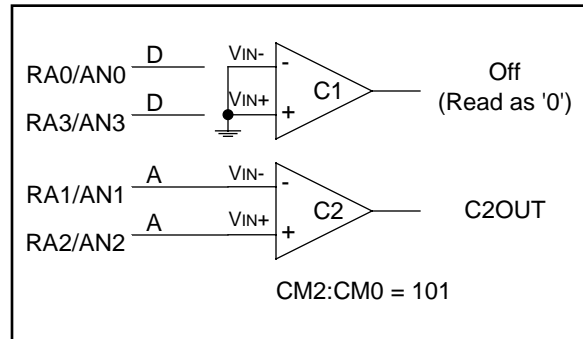

The One Independent Comparator Mode (Figure 9) turns comparator C1 off making both RA0 and RA3 digital I/O. Comparator C2 is operational with analog inputs from RA1 and RA2.

FIGURE 10: THREE INPUTS MULTIPLEXED TO TWO COMPARATORS

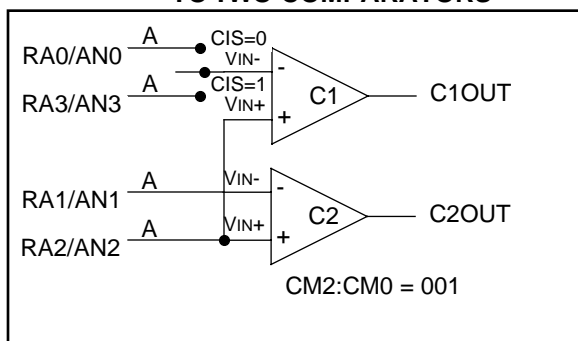

The Three Inputs Multiplexed to Two Comparators Mode (Figure 10) connects the VIN+ pin of each comparator to RA2. The VIN- pin of comparator 2 is connected to RA1. The CIS bit, CMCON<3>, controls the input to the VIN- pin of comparator 1. If CIS = 0, then RA0 is connected to the VIN- pin. Otherwise RA3 is connected to the VIN- pin of comparator 1.

Note: Each comparator that is active will consume less power when the output is at a high level.

Clearing the Comparator Interrupt Flag

The comparator interrupt flag, CMIF, is located in the PIR1 register. This flag must be cleared after changing comparator modes. Whenever the comparator mode or the CIS bit is changed, the CMIF may be set due to the internal circuitry switching between modes. Therefore, comparator interrupts should be disabled before changing modes. Then, a delay of 10 μ s should be used after changing modes to allow the comparator circuitry to stabilize.

The steps to clear the CMIF flag when changing modes are as follows:

- Change the comparator mode or CIS bit
- 10 μ s delay
- Read the CMCON register to end the “mismatch” condition
- Clear the CMIF bit of the PIR1 register

The value of C1OUT and C2OUT are internally latched on every read of the CMCON register. The current values of C1OUT and C2OUT are compared with the latched values, and when these values are different a “mismatch” condition occurs. The CMIF interrupt flag will not be cleared if the CMCON register has not been read.

Using the Comparator Module

The CMCON register contains the comparator output bits C1OUT and C2OUT, CMCON<7:6>. These bits are read only. C1OUT and C2OUT follow the output of the comparators and are not synchronized to any internal clock edges. Therefore, the firmware will need to maintain the status of these output bits to determine the actual change that has occurred. The PIR1 register contains the comparator interrupt flag CMIF, PIR1<6>. The CMIF bit is set whenever there is a change in the output value of either comparator relative to the last time the CMCON register was read.

Note: If a change in C1OUT or C2OUT should occur when a read operation on the CMCON register is being executed (start of the Q2 pcycle), the CMIF interrupt flag may not be set.

When reading the PORTA register, all pins configured as analog inputs will read as a '0'. Analog levels on any pin that is defined as a digital input may cause the input buffer to consume more current than is specified.

The code in Example 1 shows the steps required to configure the comparator module. RA3 and RA4 are configured as digital outputs. RA0 and RA1 are configured as the VIN- inputs to the comparators and RA2 is the VIN+ input to both comparators.

EXAMPLE 1: INITIALIZING THE COMPARATOR MODULE

```
CLRF   PORTA           ;init PORTA
MOVLW  0X03           ;Two Common
MOVWF  CMCON          ;Reference
                          ;Comparators
                          ;mode selected
BSF    STATUS,RP0     ;go to Bank 1
MOVLW  0X07           ;Set RA<2:0> as
MOVWF  TRISA          ;inputs,RA<4:3>
                          ;as outputs
BCF    STATUS,RP0     ;go to Bank 0
CALL   DELAY10        ;10 $\mu$ s delay
MOVF   CMCON,F        ;read the CMCON
BCF    PIR1,CMIF      ;clear the CMIF
BSF    STATUS,RP0     ;go to Bank 1
BSF    PIE1,CMIE      ;enable compar-
                          ;ator interrupt
BCF    STATUS,RP0     ;go to Bank 0
BSF    INTCON,PEIE    ;enable global
BSF    INTCON,GIE     ;and peripheral
                          ;interrupts
```

The comparators will remain active if the device is placed in sleep mode, except for the Comparators Off Mode (CM2:CM0 = 111) and Comparators Reset Mode (CM2:CM0 = 000). In these modes the comparators are turned off and are in a low power state. A comparator interrupt, if enabled, will wake-up the device from sleep in all modes except **Off** and **Reset**.

AN611

Comparator Timings

The comparator module has a response time and a mode change to output valid timing associated with it. The response time is defined as the time from when an input to the comparator changes until the output of that comparator becomes valid. The response time is faster when the output of the comparator transitions from a high level to a low level. The mode change to output valid time refers to the amount of time it takes for the output of the comparators to become valid after the mode has changed. The internal voltage reference may contribute some delay if used in conjunction with the comparators (see Voltage Reference Settling Time).

VOLTAGE REFERENCE MODULE

The voltage reference is a 16-tap resistor ladder network that is segmented to provide two ranges of VREF values. Each range has 16 distinct voltage levels. The voltage reference has a power-down function to conserve power when the reference is not being used. The voltage reference also has the capability to be connected to RA2 as an output. Figure 11 shows the Voltage Reference Control Register (VRCON) register which controls the voltage reference. Figure 12 shows the block diagram for the voltage reference module.

FIGURE 11: VRCON REGISTER

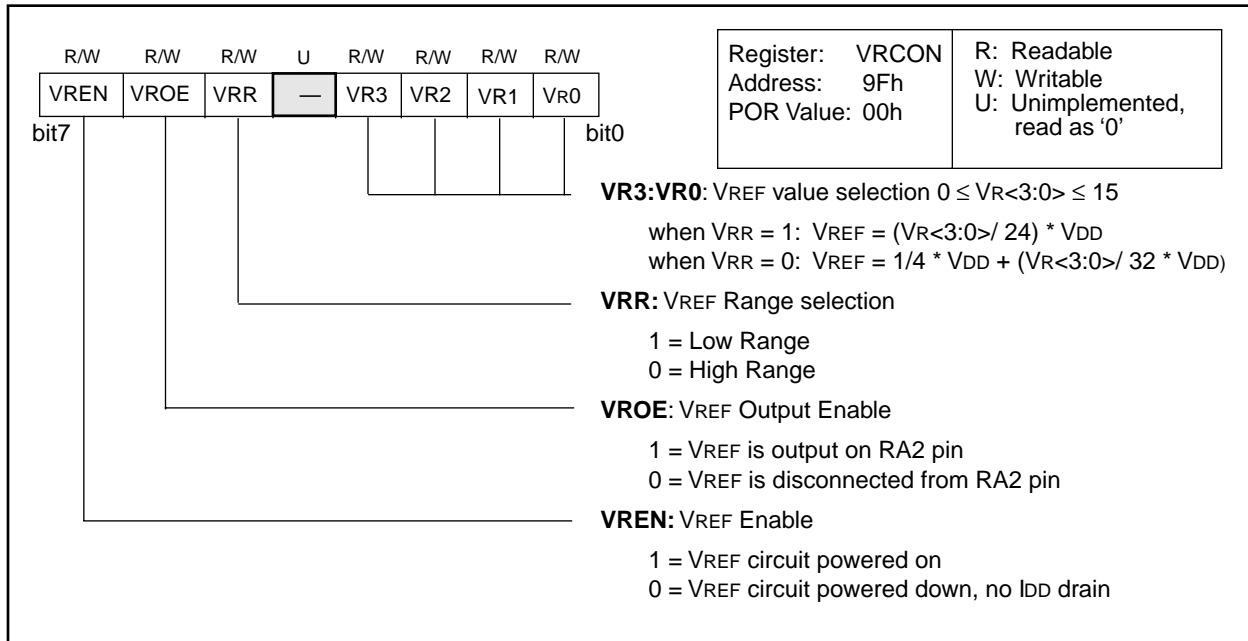
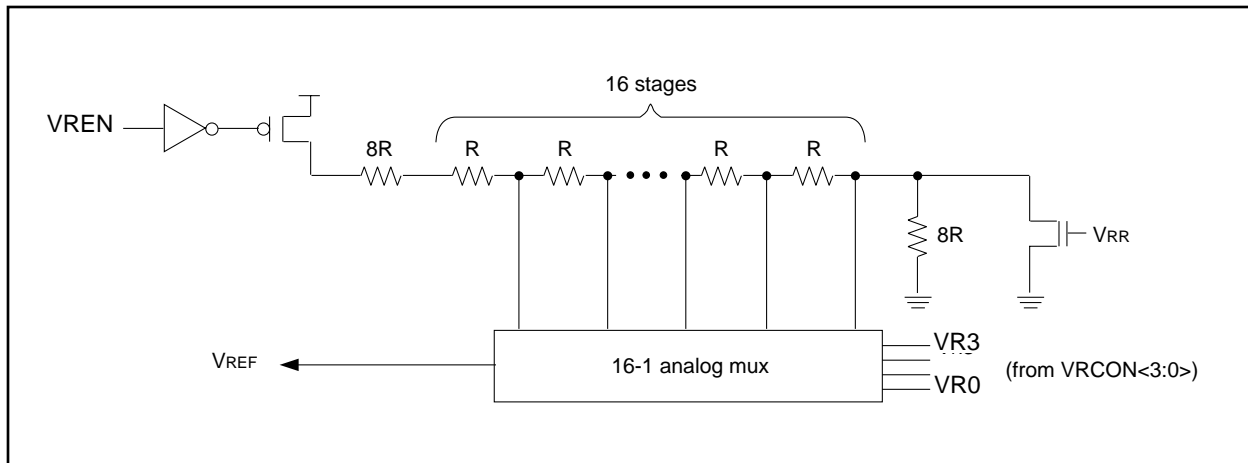

FIGURE 12: VOLTAGE REFERENCE BLOCK DIAGRAM



Note: The voltage reference is VDD derived and therefore, the VREF output changes with fluctuations in VDD.

Using the Voltage Reference

The voltage reference module operates independently of the comparator module. The output of the voltage reference may be connected to the RA2 pin at any time by setting the TRISA<2> bit and the VRCON<6> bit (VROE). It should be noted that enabling the voltage reference with an input signal present will increase current consumption. Configuring the RA2 pin as a digital output with the VREF output enabled will also increase current consumption. The increases in current are caused by the voltage reference output conflicting with an input signal or the digital output. The amount of increased current consumption is dependent on the setting of VREF and the value of the input signal or the digital output.

The full range of VSS to VDD cannot be realized due to the construction of the module (Figure 12). The transistors on the top and bottom of the resistor ladder network keep VREF from approaching VSS or VDD. Equation 1 and Equation 2 are used to calculate the output of the voltage reference.

EQUATION 1: VOLTAGE REFERENCE EQUATION, VRR = 1

$$V_{REF} = (VR<3:0>/24) \times V_{DD}$$

EQUATION 2: VOLTAGE REFERENCE EQUATION, VRR = 0

$$V_{REF} = (V_{DD}/4) + (VR<3:0>/32) \times V_{DD}$$

An example of how to configure the voltage reference is given in Equation 2. The reference is set for an output voltage of 1.25V at a VDD of 5.0V.

EXAMPLE 2: VOLTAGE REFERENCE CONFIGURATION

```
MOVLW 0X02      ;4 Inputs Muxed
MOVWF CMCON     ;to 2 comps.
BSF STATUS,RP0 ;go to Bank 1
MOVLW 0x07     ;RA3-RA0 are
MOVWF TRISA    ;outputs
MOVLW 0XA6     ;enable VREF,
MOVWF VRCON    ;low range
                ;set VR<3:0>=6
BCF STATUS,RP0 ;go to Bank 0
CALL DELAY10   ;10µs delay
```

If the voltage reference is used with the comparator module, the following steps should be followed when making changes to the voltage reference.

1. Disable the comparator interrupts
2. Make changes to the voltage reference
3. Delay 10 µs to allow VREF to stabilize
4. Delay 10 µs to allow comparators to settle
5. Clear the comparator interrupt flag
 - Read the CMCON register
 - Clear the CMIF bit
6. Enable comparator interrupts

The output of the voltage reference may be used as a simple DAC. However, the VREF output has limited drive capability when connected to the RA2 pin. In fact the amount of drive the voltage reference can provide is dependent on the setting of the tap on the resistor ladder. If VREF is used as an output, an external buffer must be used.

Voltage Reference Settling Time

Settling time of the voltage reference is defined as the time it takes the output voltage to settle within 1/4 LSB after making a change to the reference. The changes include adjusting the tap position on the resistor ladder, enabling the output, and enabling the reference itself. If the voltage reference is used with the comparator module, the settling time must be considered.

MAKING SIMPLE A/D CONVERSIONS

Linear slope integrating A/D converters are very simple to implement and can achieve high linearity and resolution for low conversion rates. The three types of converters that will be discussed are the single-slope, dual-slope, and modified single-slope converters. The following material was referenced from application note AN260, "A 20-Bit (1ppm) Linear Slope-Integrating A/D Converter", found in the Linear Applications Handbook from National Semiconductor®.

Single-Slope Integrating Converter

A single-slope integrating converter is shown in Figure 13. In a single-slope converter, a linear ramp is compared against an unknown input V_{AIN} . When the switch $S1$ is opened the ramp begins. The time interval between the opening of the switch and the comparator changing state is proportional to the value of V_{AIN} .

The basic assumptions are that the integrating capacitor $C1$ and the clock used to measure the time interval remain constant over time and temperature. This type of converter is heavily dependent on the stability of the integrating capacitor.

FIGURE 13: SINGLE-SLOPE INTEGRATING CONVERTER

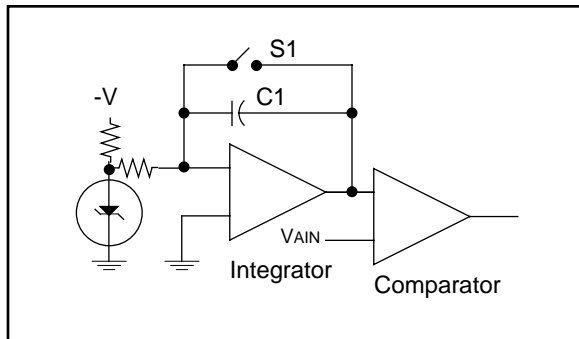

Dual-Slope Integrating Converter

Figure 14 shows a dual-slope integrating converter. The dual-slope converter integrates the V_{AIN} input for a predetermined length of time. The voltage reference is then switched into the integrator input, using $S2$, which integrates in a negative direction from the V_{AIN} slope. The length of time the reference slope requires to return to zero is proportional to the value of V_{AIN} . Both slopes are made with the same integrating capacitor $C1$ and measured with the same clock, so they need only to be stable over one conversion cycle.

FIGURE 14: DUAL-SLOPE INTEGRATING CONVERTER

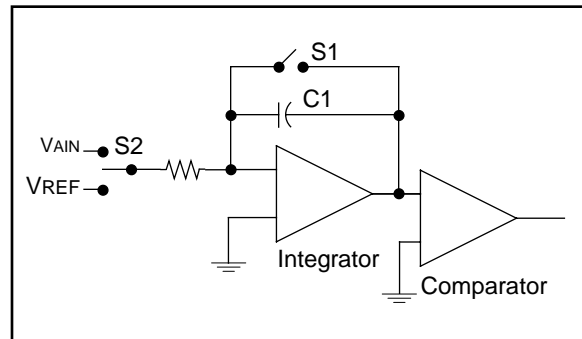

The dual-slope converter essentially removes the stability factor of the integrating capacitor from a conversion, however, the dielectric absorption of $C1$ has a direct effect. Dielectric absorption not only creates residual non-linearity in the dual-slope converter, but causes the converter to output different values for a fixed input as the conversion rate is varied. Dielectric absorption is defined as the capacitor dielectric's unwillingness to accept or give up charge instantaneously. This effect is modeled as a parasitic RC network across the main capacitor. A charged capacitor will require some time to discharge, even through a dead short, due to the parasitic RC network and some amount of charge will be absorbed by the parasitic C after charging of the main capacitor has stopped. Typically, Teflon, polystyrene and polypropylene dielectrics offer better performance than paper, mylar, or glass. Electrolytics have the worst dielectric absorption characteristics and should be avoided for use in slope integrating converters.

Modified Single-Slope Converter

The modified single-slope converter has been designed to compensate for the effects present in the previous converters. Resolutions of up to 16-bits can be achieved using high precision components and voltage reference source. Figure 15 shows the modified single-slope converter. Some features of this converter are:

- Continuously corrects for zero and full-scale drifts in all components of the circuit.
- The integrating capacitor C1 is charged periodically and always in the same direction. The error induced from dielectric absorption will be small and can be compensated by using an offset term in the calibration procedure.
- The ramp voltage always approaches the comparator trip point from the same direction and slew rate.
- There is no noise rejection capability because the input signal is directly coupled to the comparator input. A filter at the comparator input would cause a delay due to the settling time of the filter.

FIGURE 15: MODIFIED SINGLE-SLOPE INTEGRATING CONVERTER

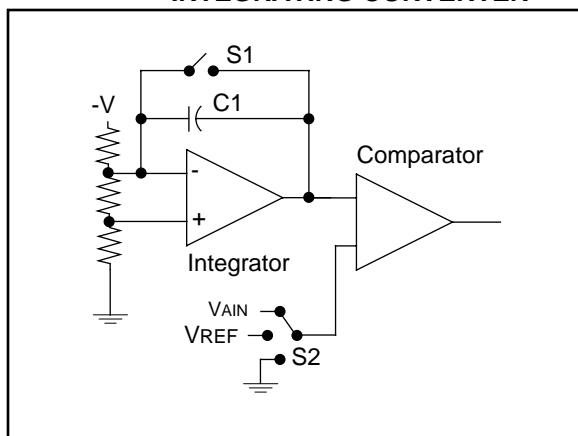

The microcontroller sends a periodic signal to switch S1 regardless of the operating mode of the system. The output of the integrator is a fixed-frequency period and height signal which is fed into the input of the comparator. The time between ramps is long enough to allow integrating capacitor C1 to discharge completely. The other input is multiplexed with ground, reference, and VAIN through switch S2. When the microcontroller starts a conversion, the ground signal is switched into the comparator and the time for the ramp to cross zero is measured and stored. The same measurements are repeated for the reference and VAIN signals. Assuming that the integrator ramps are highly linear, Equation 3 is used to determine the value of VAIN.

EQUATION 3: OUTPUT EQUATION FOR THE MODIFIED-SLOPE CONVERTER

$$V_{AIN} = \frac{t_{AIN} - t_{GND}}{t_{VREF} - t_{GND}} \times K \text{ mV}$$

where t_{AIN} is the measured time for the VAIN signal, t_{VREF} is the measured time for the voltage reference signal, t_{GND} is the measured time for the ground signal, and K is a constant (typically 10^7).

APPLICATION CIRCUIT

The application circuit, called PICMETER, uses a PIC16C622 as a resistance and capacitance meter. The PICMETER uses a variation of the single-slope integrating converter. The linear slope and integrator of Figure 13 are replaced with the exponential charge waveform of an RC. The charge time of a known component is compared against the charge time of an unknown component to determine the value of the unknown component.

A schematic of the PICMETER is shown in Figure 16. All reference designators cited in this section refer to this schematic. Results are transmitted to a PC which displays the value measured. The PICMETER can measure resistance in the range 1Ω to 999Ω and capacitance from 1 nF to 999 nF .

The following sections describe, in detail, the hardware, firmware, and PC software used in the application circuit. Appendix A shows the PICMETER firmware and Appendix B has the PC software. Appendix C contains the PCB layout.

AN611

FIGURE 16: PICMETER SCHEMATIC

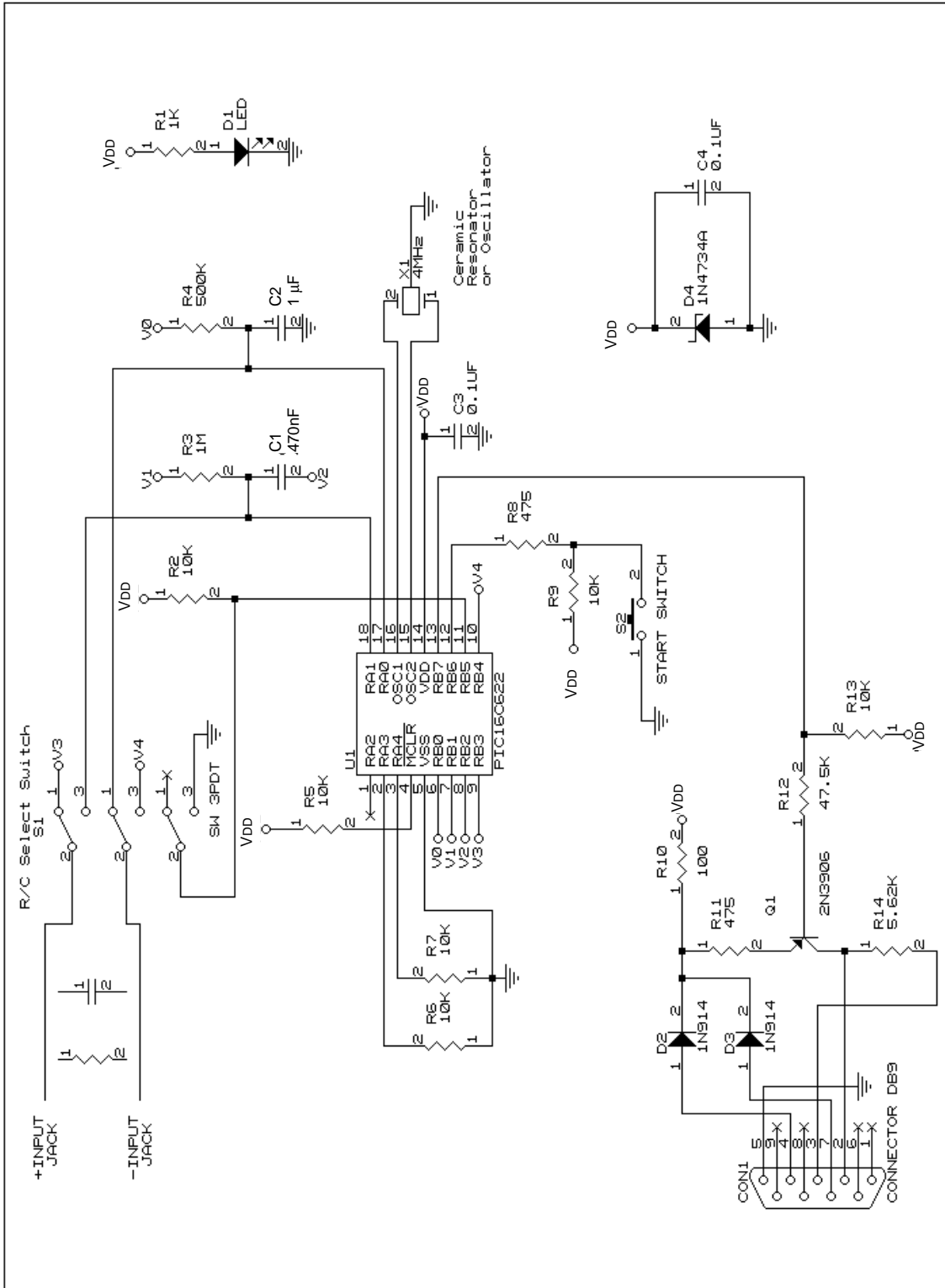

Power

The RS-232 serial port provides power to the PICMETER. The RTS and DTR lines from the serial port output 3V to 11V to the PICMETER. The diodes D2 and D3 prevent any damage to the PC's serial port. Resistor R10 is used to current limit the Zener diode, D4. D4 is used to regulate the RTS and DTR voltage to 5.6V. Capacitors C3 and C4 provide power supply filtering to the Zener diode and the PIC16C622. This method of supplying power to devices using a serial port, such as a trackball or mouse, is very simple considering that the PICMETER requires approximately 7 mA to function.

Switches

Switch S1 is used to select either a resistor or capacitor measurement. RB5 of the PIC16C622 is used to detect what type of component is being measured. This switch also swaps the unknown component into the RC network.

If a resistor is the unknown component and a capacitor measurement is requested, the circuit reduces to a resistor divider on the V_{IN-} pin of the comparator. This would result in a measured value of 0 pF if the voltage on the resistor divider network is greater than the voltage reference setting. Otherwise an error is detected. If a capacitor is the unknown component and a resistor measurement is selected, the circuit reduces to a capacitor divider network on the V_{IN-} pin of the comparator. This case will also produce an error message.

Resistor measurements that are started without any component connected to the measuring terminals will cause an error. Capacitor measurements without a component connected to the measuring terminals will give a result of 0 pF.

Switch S2 is used to initiate a measurement. The switch is connected to RB6 of the PIC16C622 and the PORTB wake-up on change interrupt is used to detect a key press. A modified version of the firmware in AN552, "Implementing Wake-up on Key Stroke" was used to control the interrupt.

Measuring the Charge Time

The procedures for measuring a resistor or capacitor are the same except for the I/O pins used to control the RC networks. This also applies when measuring a known or unknown component.

Measurement Overview

The charge time of the unknown RC network is measured using Timer0. This value is multiplied by the known value of resistance or capacitance and stored in an accumulator. Then the charge time of the known RC network is measured. The accumulator is divided by the known RC network charge time to give the value of resistance or capacitance of the unknown component. Equation 4 shows the equation used to calculate resistance and Equation 5 shows the capacitance equation.

EQUATION 4: RESISTANCE EQUATION

$$R_{UNK} = \frac{t_{UNK} \times R_{KN}}{t_{KN}}$$

EQUATION 5: CAPACITANCE EQUATION

$$C_{UNK} = \frac{t_{UNK} \times C_{KN}}{t_{KN}}$$

R_{UNK} and C_{UNK} are the unknown resistor and capacitor values. R_{KN} and C_{KN} are the known resistor and capacitor values. t_{UNK} and t_{KN} are the charge times for the unknown and known components.

Detailed Measurement Description

The first step in measuring the charge time of either the known or the unknown RC networks is to reconfigure the I/O pins. The default state of the PORTA and PORTB pins connected to the RC network are all grounded outputs. This discharges all capacitors in the RC networks. The unknown component is measured first, so the known component, R4 or C1, is removed from the RC network. This is accomplished by making RB0 or RB2 on the PIC16C622 an input. Connections to the other RC network are kept grounded.

The analog modules are now initialized. The mode of the comparators is set to Four Inputs Multiplexed to Two Comparators (Figure 6). The CIS bit, CMCON<3> is cleared to select RA0 as the VIN- input to comparator 1 and RA1 as the VIN- input to comparator 2. The voltage reference is enabled, the output is disabled, and the high range is selected. The tap on the resistor ladder is set to 12. The value of 12 was selected because it is the lowest value of VREF that will trip the comparators, yet gives a time constant long enough to achieve good resolution for the measurement. After a 20 msec delay, which allows the analog modules to stabilize, the comparator flag is cleared. Comparator interrupts are enabled and Timer0 is cleared. Finally, the PEIE bit is set to enable comparator interrupts and the GIE bit is set to enable interrupts.

Now that the analog systems are ready, Timer0 is cleared again and power is applied to the unknown RC network by setting RB1 or RB3 high. Timer0 begins to increment a set of three registers which are cascaded together. These registers contain the charge time of the component. While waiting for the DONE flag, the ERROR flag is checked. See the Error Message section for an explanation of error detection. When the capacitor voltage trips the comparator, Timer0 is prevented from further incrementing the time registers and the DONE flag is set. The value in the time registers is τ_{UNK} .

The analog modules are now disabled. The comparator interrupts are disabled and the comparators are turned off (CM2:CM0=111). RA0 through RA3 and RB0 through RB4 are set up as grounded outputs to discharge the capacitors in the RC networks. This prevents a false reading during the next measurement. The voltage reference is disabled to conserve power and all interrupt flags are cleared. Extra delay loops are added at this time to ensure that the capacitors are discharged.

The charge time, τ_{UNK} , is then multiplied by the value of known resistance or capacitance. These values, in pF or Ω , were obtained by measuring the known RC networks with a Fluke meter. Each of these values is a 24-bit number. The result of multiplication is a 56-bit number which is stored in accumulators ACCb (most significant 24-bits) and ACCc (least significant 24-bits).

The process now repeats itself, except this time the charge time of the known RC network is measured. Now the unknown component is removed from the RC network by making the connections from the PIC16C622 inputs. The analog modules are initialized and the same procedure explained above is followed to measure the charge time of the known RC network. The 56-bit result previously stored in accumulators ACCb and ACCc is now divided by the charge time of the known component, τ_{KN} . This result is a 24-bit number which has the units of pF or Ω . This value is then transmitted to the PC.

RS-232 Transmission

PICMETER uses a transmit only, software implemented serial port adapted from AN593, "Serial Port Routines Without Using the TMRO". Hardware hand-shaking is not used. Since the serial port is realized in software, all interrupts must be disabled during transmission otherwise the baud rate can get corrupted.

On power-up, PICMETER sends a boot message to the PC which is "PICMETER Booted!". Otherwise, a four byte packet structure with a command byte and 3 data bytes is used. The command byte contains one of four possible commands:

- ASCII 'S' signifies that a measurement has been initiated
- ASCII 'E' tells the PC that an Error has been detected
- ASCII 'R' tells the PC that Resistance data is contained in the three data bytes
- ASCII 'C' tells the PC that Capacitance data is contained in the three data bytes

The first data byte for the 'R' and 'C' commands contain the MSB of the measured value. The last data byte contains the LSB of the measured value. The three data bytes for the commands 'S' and 'E' do not contain any useful information at this time.

An 'S' command is issued every time the start switch, S2, is pressed. PICMETER then sends an 'R' or 'C' command for a valid measurement or an 'E' command when an error is detected.

Since the PICMETER operates from a single supply voltage, a discrete transistor is used as a level shifter. This insures that a low output on the RS-232 TXD line is between -3V and -11V. When the TXD line, RB7, from the PIC16C622 is at a logic high level, the transistor Q1 is off. The RXD line of the computer will then be at approximately the same voltage as the TXD line, -11V to -3V. A logic low level from RB7 of the PIC16C622 will turn on transistor Q1. This will bring the RXD line of the computer to about the same voltage of the DTR or RTS line, +3V to +11V.

The pins of interest on the DB9 connector CON1 are:

- pin 2 - RXD
- pin 3 - TXD
- pin 4 - DTR
- pin 5 - GND
- pin 7 - RTS

RTS, DTR, and GND provide power and ground to the PICMETER. RXD is connected to the collector of transistor Q1. TXD is connected to RXD through resistor R14. Since hardware hand-shaking is not implemented on the PICMETER, DSR (pin 6) and CTS (pin 8) are left disconnected.

The demo board developed by Microchip was intended to connect directly to a 9-pin serial port. A 9-pin male-to-female cable may also be used. These boards were manufactured by Southwest Circuits located in Tucson, Arizona (Appendix C). The PCB layout for this demo board is shown in Appendix C.

Error Message

The error message is sent only when the PICMETER is making a measurement and detects an error. The range of resistance that the PICMETER measures is 1 kΩ to 999 kΩ. Using the value of C2, 1 μF, the range of charging times for resistance measurements is 1msec to 999 ms. The range of capacitor charging times is also 1 ms to 999 ms using the resistance value of R3, 1MΩ, and a capacitor measuring range of 1 nF to 999 nF. A ceramic resonator of 4 MHz gives Timer0 a resolution of 1 ns. Therefore, the highest count that the time registers should reach is 999,000. This is a 20-bit number. If the 21st bit should ever be set, it is assumed that the PICMETER is trying to measure the air gap between the measuring terminals, a component that is out of range, or switch S1 is not set correctly for the component in the measuring terminals.

24-Bit Math Routines

The 24-bit math routines were developed using simple algorithms found in any computer math book. These math routines include addition, subtraction, multiplication, division, and 2's complement. Four 24-bit accumulators located in the general purpose RAM area of the PIC16C622 are used by the math routines: ACCa, ACCb, ACCc, and ACCd. Table 2 shows the relationship between the math routines and the accumulators.

TABLE 2: MATH ROUTINE ACCUMULATORS

Name	Operation	Result	Temp. Storage
Add	ACCa + ACCb	ACCb	N/A
Subtract	2's Comp ACCa then ACCa + ACCb	ACCa	N/A
Multiply	ACCa x ACCb	ACCb (MSB's) ACCc (LSB's)	ACCd
Divide	ACCb:ACCc ACCa	quotient in ACCc remainder in ACCb	ACCd
2's Comp	NOT(ACCa) + 1	ACCa	N/A

Computer Program

The program that receives data from the PICMETER was written in Visual Basic® from Microsoft® for the Windows® environment. Figure 17 show the display of the Windows based PICMETER program.

FIGURE 17: PICMETER PC PROGRAM

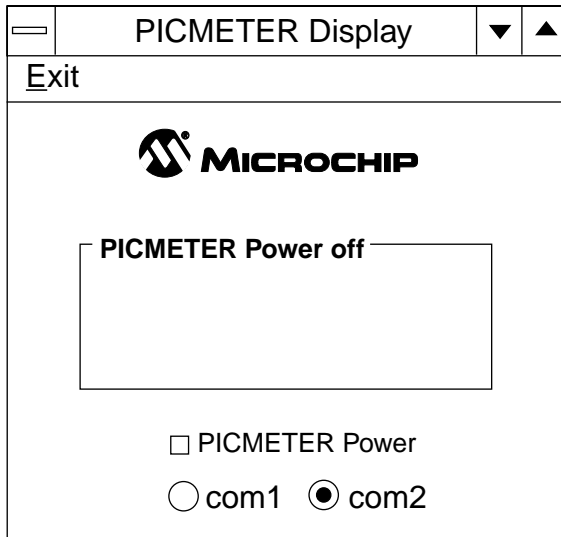

The operation of this program is simple. A functional description is given below:

- a) Select the appropriate COM port by clicking on the COM1 or COM2 buttons.
- b) Turn power on to the PICMETER by clicking on the PICMETER Power button.
- c) The frame message should read "PICMETER Booted!", the frame contents will be cleared, and the LED on the PICMETER should be on.
- d) The switch S1 selects the type of component that is in the measuring terminals.
- e) Pressing the START button, S2, on the PICMETER will initiate a measurement. The frame message should read "Measuring Component" and the contents of the frame will be cleared.
- f) When the measurement is complete, the frame message will read "Resistance" or "Capacitance" depending on the position of switch S1. The value of the component will be displayed in the frame as well as the units.
- g) If an error is detected, the frame message will read "Error Detected". This is only a measurement error. Check the component on the measuring terminals and the position of switch S1.
- h) Turn off the PICMETER by clicking on the PICMETER Power button. The frame message will change to "PICMETER Power OFF", the frame contents will be cleared, and the LED on the PICMETER will turn off.

Appendix B contains a complete listing of the Visual Basic program.

PICMETER ACCURACY

The PICMETER measures capacitance in the range of 1 nF to 999 nF. Table 3 shows a comparison of various capacitors. All capacitors have a tolerance of 10% and have various dielectrics. The average error percentage is 3%.

TABLE 3: CAPACITANCE MEASUREMENTS

Capacitance Accuracy			
Marked Value	Fluke Value	PICMETER Value	Error %
2.2 nF	2.3 nF	2.2 nF	4.3
2.5 nF	2.63 nF	2.5 nF	4.9
20 nF	16.5 nF	16.3 nF	1.2
33 nF	35.2 nF	35.8 nF	1.7
47 nF	45 nF	44.5 nF	1.1
50 nF	52 nF	52.9 nF	1.7
100 nF	99.7 nF	93 nF	6.7
0.1 μ F	95 nF	96.1 nF	1.2
0.1 μ F	99.4 nF	102.8 nF	3.4
0.22 μ F	215 nF	215.2 nF	0.1
470 nF	508 nF	518.9 nF	2.1
940 nF	922 nF	983.1 nF	6.6

The 2.5 nF, 100 nF and 940 nF capacitors all have polyester dielectric material. The Equivalent Series Resistance (ESR) of polyester capacitors is typically high which would cause the PICMETER to have a larger error than other dielectrics. If the error percentages for these capacitors is ignored, the average error decreases to 1.9%.

The resistance range of the PICMETER is 1 k Ω to 999 k Ω . Table 4, Resistance Measurements, shows a comparison of various resistors in this range. All resistors have a tolerance of 5%. The average error percentage is 1%.

TABLE 4: RESISTANCE MEASUREMENTS

Resistance Accuracy			
Marked Value	Fluke Value	PICMETER Value	Error %
1.2k	1.215k	1.2k	1.3
5.1k	5.05k	5.0k	1.0
8.2k	8.47k	8.3k	2.0
10k	10.2k	10k	2.0
15k	15.36k	15.1k	1.7
20k	20.8k	20.5k	1.5
30k	30.4k	30k	1.4
51k	50.3k	49.8k	1.0
75k	75.5k	74.8k	1.0
91k	96.4k	95.9k	0.6
150k	146.3k	145.6k	0.5
200k	195.5k	195k	0.3
300k	309k	309.5k	0.2
430k	433k	434.5k	0.4
560k	596k	599.6k	0.6
680k	705k	709.8k	0.7
820k	901k	907.3k	0.7
910k	970k	977.8k	0.8

AN611

The accuracy of the PICMETER is dependent on the range of components being measured. If auto-ranging could be implemented, the accuracy of the PICMETER could be improved. The addition of capacitors in parallel with C2 of Figure 16 would allow auto-ranging for resistor measurements. Additional resistors in parallel with R3 would give auto-ranging capability to capacitor measurements. Figure 18 shows a simple implementation of auto-ranging given that the I/O pins are available. The R? and C? are the extra components that are added to the PICMETER circuit. These components should be optimized for a particular range of devices.

FIGURE 18: AUTO-RANGING TECHNIQUE

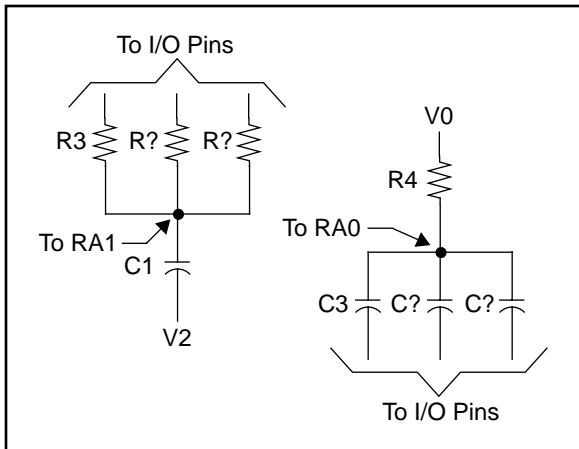

Another addition to the PICMETER that would increase the accuracy of components being measured is a constant current source. The source would feed into the resistor of the RC networks. This provides the same charging current to all RC networks being measured. Figure 19 shows a bilateral current source and Figure 20 shows a precision current source.

FIGURE 19: BILATERAL CURRENT SOURCE

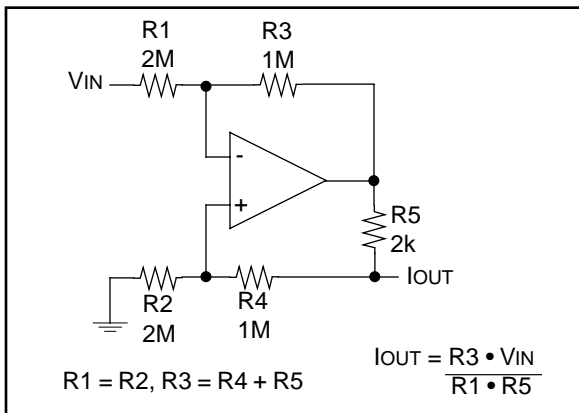
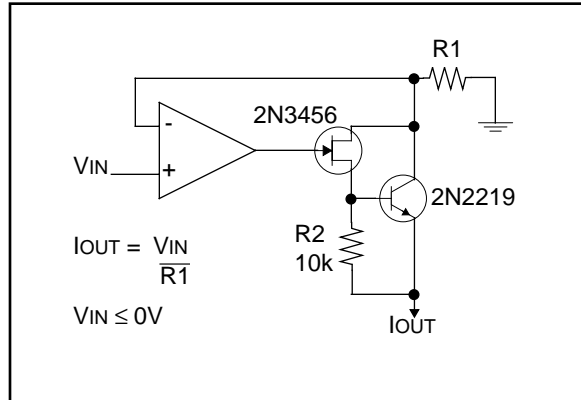
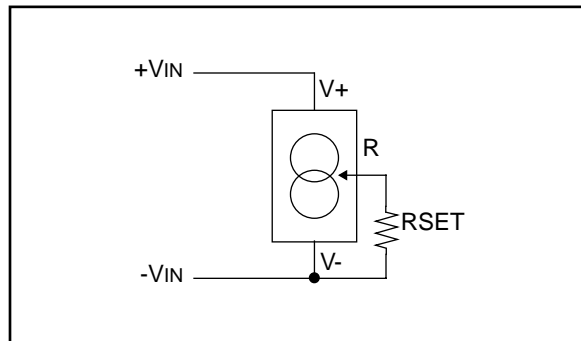

FIGURE 20: PRECISION CURRENT SOURCE



An alternative to the previous current sources is a single chip solution. A 3-terminal adjustable current source, such as a LM134/LM234/LM334 from National Semiconductor, is an ideal choice. This output current is programmable from 1 μ A to 10 mA and requires a single external resistor to set the value of current. Figure 21 shows a block diagram of the LM334Z.

FIGURE 21: LM334Z BLOCK DIAGRAM



CONCLUSION

PIC16C62X devices add two significant analog features to the PIC16CXXX mid-range family: comparators and a voltage reference. The flexibility of eight operating modes for the comparator module allows the designer to tailor the PIC16C62X device to the application. The addition of an on-chip voltage reference simplifies the design by removing at least one external component and power consumption. These analog modules coupled with the PIC16CXXX mid-range family core create a new path to achieve high resolution results.

Please check the Microchip BBS for the latest version of the source code. Microchip's Worldwide Web Address: www.microchip.com; Bulletin Board Support: MCHIPBBS using CompuServe® (CompuServe membership not required).

APPENDIX A: PICMETER FIRMWARE

MPASM 01.40 Released

PICMETER.ASM 1-16-1997 17:49:07

PAGE 1

```

LOC  OBJECT CODE      LINE SOURCE TEXT
VALUE

      00001          TITLE "PICMETER Firmware for PIC16C622"
      00002          LIST P = 16C622
      00003          ERRORLEVEL -302
      00004
      00005          INCLUDE <P16C622.INC>
      00001          LIST
      00002 ; P16C622.INC Standard Header File, Version 1.01   Microchip Technology, Inc.
      00165          LIST
      00006
2007 3FB1 00007      __CONFIG    _BODEN_OFF & _CP_OFF & _PWRTE_ON & _WDT_OFF & _XT_OSC
00008
00009 ;*****
00010 ;*-----*
00011 ;*-                                     -*
00012 ;*-      PICMETER - Resistance and Capacitance Meter                -*
00013 ;*-                                     -*
00014 ;*-----*
00015 ;*-                                     -*
00016 ;*-      Author:      Rodger Richey                                -*
00017 ;*-      Applications Engineer                                     -*
00018 ;*-      Filename:    picmeter.asm                                  -*
00019 ;*-      Revision:    1 May 1995                                    -*
00020 ;*-      1-16-97      ; For compatibility with MPASMWIN 1.40      -*
00021 ;*-                                     -*
00022 ;*-----*
00023 ;*-                                     -*
00024 ;*- PICMETER is based on a PIC16C622 which has two comparators and a -*
00025 ;*- variable voltage reference. Resistance and capacitance is        -*
00026 ;*- calculated by measuring the time constant of a RC network. The    -*
00027 ;*- toggle switch selects either resistor or capacitor input. The    -*
00028 ;*- pushbutton switch starts a measurement. The time constant of the -*
00029 ;*- unknown component is compared to that of known component to      -*
00030 ;*- calculate the value of the unknown component. The following      -*
00031 ;*- formulas are used:
00032 ;*-
00033 ;*-      Resistance:      Ru = ( Rk * Tu ) / Tk                        -*
00034 ;*-      Capacitance:    Cu = ( Ck * Tu ) / Tk                        -*
00035 ;*-                                     -*
00036 ;*-----*
00037 ;*****
00038
00039
00040 ;*****
00041 ;*-----*
00042 ;*-      RS232 code borrowed from Application Note AN593              -*
00043 ;*-      "Serial Port Routines Without Using Timer0"                  -*
00044 ;*-      Author:      Stan D'Souza                                    -*
00045 ;*-                                     -*
00046 ;*-----*
003D0900 00047 xtal    equ    .4000000
00002580 00048 baud    equ    .9600
000F4240 00049 fclk    equ    xtal/4
00050 ;*****
00051 ;The value baudconst must be a 8-bit value only
00000020 00052 baudconst equ    ((fclk/baud)/3-2)

```

AN611

```
00053 ;*****
00054
00055
00056 ;*****
00057 ;      Bit Equates
00058 ;*****
0000000 00059 BEGIN   equ    0           ;begin a measurement flag
0000007 00060 DONE   equ    7           ;done measuring flag
0000005 00061 WHICH  equ    5           ;R or C measurement flag
0000003 00062 F_ERROR equ    3           ;error detection flag
0000005 00063 EMPTY  equ    5           ;flag if component is connected
0000000 00064 V0     equ    0           ;power for R reference ckt
0000001 00065 V1     equ    1           ;power for C reference ckt
0000002 00066 V2     equ    2           ;ground for C reference ckt
0000003 00067 V3     equ    3           ;power for unknown R ckt
0000004 00068 V4     equ    4           ;ground for unknown C ckt
0000007 00069 msb_bit equ    7           ;define for bit 7
0000000 00070 lsb_bit equ    0           ;define for bit 0
0000007 00071 RKHI   equ    0x07        ;value of the known resistance, R4, in ohms
000009D 00072 RkMID  equ    0x9D        ;measured by a Fluke meter
0000038 00073 RkLO   equ    0x38
0000007 00074 CKHI   equ    0x07        ;value of the known capacitance, C1, in pF
0000047 00075 CkMID  equ    0x47        ;measured by a Fluke meter
0000048 00076 CkLO   equ    0x48
00077
00078 ;*****
00079 ;      User Registers
00080 ;*****
00081 ;      Bank 0
0000020 00082 W_TEMP  equ    0x20        ;Bank 0 temporary storage for W reg
0000021 00083 STATUS_TEMP equ 0x21        ;temporary storage for STATUS reg
0000023 00084 Ttemp   equ    0x23        ;temporary Time register
0000024 00085 flags    equ    0x24        ;flags register
0000025 00086 count   equ    0x25        ;RS232 register
0000026 00087 txreg   equ    0x26        ;RS232 data register
0000027 00088 delay   equ    0x27        ;RS232 delay register
0000028 00089 offset  equ    0x28        ;table position register
0000029 00090 msb     equ    0x29        ;general delay register
000002A 00091 lsb     equ    0x2A        ;general delay register
0000040 00092 TimeLO  equ    0x40        ;Time registers
0000041 00093 TimeMID equ    0x41
0000042 00094 TimeHI  equ    0x42
00095
00096 ;      Math related registers
0000050 00097 ACCaHI  equ    0x50        ;24-Bit accumulator a
0000051 00098 ACCaMID equ    0x51
0000052 00099 ACCaLO  equ    0x52
0000053 00100 ACCbHI  equ    0x53        ;24-Bit accumulator b
0000054 00101 ACCbMID equ    0x54
0000055 00102 ACCbLO  equ    0x55
0000056 00103 ACCcHI  equ    0x56        ;24-Bit accumulator c
0000057 00104 ACCcMID equ    0x57
0000058 00105 ACCcLO  equ    0x58
0000059 00106 ACCdHI  equ    0x59        ;24-Bit accumulator d
000005A 00107 ACCdMID equ    0x5A
000005B 00108 ACCdLO  equ    0x5B
000005C 00109 temp   equ    0x5C        ;temporary storage
00110
00111 ;      User Registers Bank 1
00112 ;W_TEMP  equ    0xA0           ;Bank 1 temporary storage for W reg
00113
00114 ;      User defines
00115 #define tx      PORTB,7         ;define for RS232 TXD output pin
00116
00117 ;*****
00118
```

```

0000          00119      org      0x0
0000 2810     00120      goto    init
              00121
0004          00122      org      0x4
0004 28B9     00123      goto    ServiceInterrupts
              00124
0010          00125      org      0x10
0010          00126      init
0010 1283     00127      bcf     STATUS,RP0      ;select bank 0
0011 0185     00128      clrf   PORTA           ;clear PORTA and PORTB
0012 0186     00129      clrf   PORTB
0013 1786     00130      bsf     tx              ;set TXD output pin
0014 01A4     00131      clrf   flags          ;clear flags register
0015 3010     00132      movlw  0x10           ;load table offset register
0016 00A8     00133      movwf  offset
0017 018B     00134      clrf   INTCON         ;clear interrupt flags and disable interrupts
0018 3007     00135      movlw  0x07           ;turn off comparators, mode 111
0019 009F     00136      movwf  CMCON
001A 2140     00137      call   delay20        ;wait for comparators to settle
001B 089F     00138      movf   CMCON,F
001C 130C     00139      bcf     PIR1,CMIF
001D 1683     00140      bsf     STATUS,RP0    ;select bank 1
001E 3088     00141      movlw  0x88           ;WDT prescaler,internal TMR0 increment
001F 0081     00142      movwf  OPTION_REG
0020 0185     00143      clrf   TRISA          ;PORTA all outputs, discharges RC ckts
0021 3060     00144      movlw  0x60           ;PORTA<7,4:0> outputs, PORTA<6:5> inputs
0022 0086     00145      movwf  TRISB
0023 300C     00146      movlw  0x0C           ;setup Voltage Reference
0024 009F     00147      movwf  VRCON
0025 1283     00148      bcf     STATUS,RP0    ;select bank 0
0026 3008     00149      movlw  0x08           ;enable RBIE interrupt
0027 008B     00150      movwf  INTCON
0028 213D     00151      call   vlong          ;delay before transmitting boot message
0029 213D     00152      call   vlong          ;to allow computer program to setup
002A 213D     00153      call   vlong
002B 2131     00154      call   BootMSG        ;transmit boot message
002C 178B     00155      bsf     INTCON,GIE    ;enable global interrupt bit
              00156
002D          00157      start
002D 1C24     00158      btfss  flags,BEGIN    ;wait for a start measurement key press
002E 282D     00159      goto   start
002F 1024     00160      bcf     flags,BEGIN    ;clear start measurement flag
              00161
0030 138B     00162      bcf     INTCON,GIE    ;transmit a start measurement message
0031 3053     00163      movlw  'S'            ;to the PC
0032 20AD     00164      call   Send
0033 178B     00165      bsf     INTCON,GIE
              00166
0034 01C2     00167      clrf   TimeHI         ;reset Time registers
0035 01C1     00168      clrf   TimeMID
0036 01C0     00169      clrf   TimeLO
0037 1E86     00170      btfss  PORTB,WHICH    ;detect if resistor or capacitor measure
0038 2862     00171      goto   Capacitor
              00172
0039          00173      Resistor
0039 1683     00174      bsf     STATUS,RP0    ;set V0 to input
003A 1406     00175      bsf     TRISB,V0
003B 1283     00176      bcf     STATUS,RP0
003C 20FB     00177      call   AnalogOn       ;turn analog on
003D 0181     00178      clrf   TMR0
003E 0000     00179      nop
003F 1586     00180      bsf     PORTB,V3      ;turn power on to unknown RC ckt
0040 19A4     00181      RwaitU btfsc  flags,F_ERROR ;detect if an error occurs
0041 288B     00182      goto   ErrorDetect
0042 1FA4     00183      btfss  flags,DONE     ;measurement completed flag
0043 2840     00184      goto   RwaitU

```

AN611

```
0044 13A4    00185    bcf     flags,DONE    ;clear measurement completed flag
0045 2111    00186    call    AnalogOff    ;turn analog off
                                00187
0046 2126    00188    call    SwapTtoA    ;swap Time to accumulator a
0047 3007    00189    movlw   RkHI        ;swap known resistance value
0048 00D3    00190    movwf  ACCbHI      ;to accumulator b
0049 309D    00191    movlw   RkMID
004A 00D4    00192    movwf  ACCbMID
004B 3038    00193    movlw   RkLO
004C 00D5    00194    movwf  ACCbLO
004D 2230    00195    call    Mpy24       ;multiply accumulator a and b
                                00196
004E 1683    00197    bsf     STATUS,RP0   ;set V3 to input
004F 1586    00198    bsf     TRISB,V3
0050 1283    00199    bcf     STATUS,RP0
0051 20FB    00200    call    AnalogOn    ;turn analog on
0052 0181    00201    clrf   TMR0
0053 0000    00202    nop
0054 1406    00203    bsf     PORTB,V0     ;turn power on to known RC ckt
0055 19A4    00204 RwaitK  btfsc  flags,F_ERROR ;detect if an error occurs
0056 288B    00205    goto   ErrorDetect
0057 1FA4    00206    btfss  flags,DONE   ;measurement completed flag
0058 2855    00207    goto   RwaitK
0059 13A4    00208    bcf     flags,DONE   ;clear measurement completed flag
005A 2111    00209    call    AnalogOff    ;turn analog off
                                00210
005B 2126    00211    call    SwapTtoA    ;swap Time to accumulator a
005C 224B    00212    call    Div24       ;divide multiply by known time
                                00213
005D 138B    00214    bcf     INTCON,GIE   ;disable all interrupts
005E 3052    00215    movlw   'R'        ;transmit, for R measurement
005F 20AD    00216    call    Send
0060 178B    00217    bsf     INTCON,GIE   ;enable global interrupt bit
0061 282D    00218    goto   start       ;restart
                                00219
0062        00220 Capacitor
0062 1683    00221    bsf     STATUS,RP0   ;set V2 to input
0063 1506    00222    bsf     TRISB,V2
0064 1283    00223    bcf     STATUS,RP0
0065 20FB    00224    call    AnalogOn    ;turn analog on
0066 0181    00225    clrf   TMR0
0067 0000    00226    nop
0068 1486    00227    bsf     PORTB,V1     ;turn power on to unknown RC ckt
0069 19A4    00228 CwaitU  btfsc  flags,F_ERROR ;detect if an error occurs
006A 288B    00229    goto   ErrorDetect
006B 1FA4    00230    btfss  flags,DONE   ;measurement completed flag
006C 2869    00231    goto   CwaitU
006D 13A4    00232    bcf     flags,DONE   ;clear measurement completed flag
006E 2111    00233    call    AnalogOff    ;turn analog off
                                00234
006F 2126    00235    call    SwapTtoA    ;swap Time to accumulator a
0070 3007    00236    movlw   CkHI        ;swap known resistance value
0071 00D3    00237    movwf  ACCbHI      ;to accumulator b
0072 3047    00238    movlw   CkMID
0073 00D4    00239    movwf  ACCbMID
0074 3048    00240    movlw   CkLO
0075 00D5    00241    movwf  ACCbLO
0076 2230    00242    call    Mpy24       ;multiply accumulator a and b
                                00243
0077 1683    00244    bsf     STATUS,RP0   ;set V3 to input
0078 1606    00245    bsf     TRISB,V4
0079 1283    00246    bcf     STATUS,RP0
007A 20FB    00247    call    AnalogOn    ;turn analog on
007B 0181    00248    clrf   TMR0
007C 0000    00249    nop
007D 1486    00250    bsf     PORTB,V1     ;turn power on to known RC ckt
```

```

007E 19A4    00251 CwaitK   btfsc   flags,F_ERROR ;detect if an error occurs
007F 288B    00252         goto    ErrorDetect
0080 1FA4    00253         btfss   flags,DONE ;measurement completed flag
0081 287E    00254         goto    CwaitK
0082 13A4    00255         bcf     flags,DONE ;clear measurement completed flag
0083 2111    00256         call    AnalogOff ;turn analog off
           00257
0084 2126    00258         call    SwapTtoA ;swap Time to accumulator a
0085 224B    00259         call    Div24 ;divide multiply by known time
           00260
0086 138B    00261         bcf     INTCON,GIE ;disable all interrupts
0087 3043    00262         movlw  'C' ;transmit, for C measurement
0088 20AD    00263         call    Send
0089 178B    00264         bsf     INTCON,GIE ;enable global interrupt bit
008A 282D    00265         goto    start ;restart
           00266
008B         00267 ErrorDetect
008B 1283    00268         bcf     STATUS,RP0 ;disable TMR0
008C 128B    00269         bcf     INTCON,T0IE
008D 110B    00270         bcf     INTCON,T0IF
008E 2111    00271         call    AnalogOff ;turn analog off
008F 11A4    00272         bcf     flags,F_ERROR ;clear error flag
           00273
0090 138B    00274         bcf     INTCON,GIE ;disable all interrupts
0091 3045    00275         movlw  'E' ;transmit, for C measurement
0092 20AD    00276         call    Send
0093 178B    00277         bsf     INTCON,GIE ;enable global interrupt bit
0094 282D    00278         goto    start ;restart
           00279
00280 ;*****
00281 ;*-----*
00282 ;*- RS232 Transmit Routine -*
00283 ;*- Borrowed from AN593, "Serial Port Routines Without Using Timer0" -*
00284 ;*- Author: Stan D'Souza -*
00285 ;*- This is the routine that interfaces directly to the hardware -*
00286 ;*-----*
00287 ;*****
0095         00288 Transmit
0095 1283    00289         bcf     STATUS,RP0
0096 00A6    00290         movwf  txreg
0097 1386    00291         bcf     tx ;send start bit
0098 3020    00292         movlw  baudconst
0099 00A7    00293         movwf  delay
009A 3009    00294         movlw  0x9
009B 00A5    00295         movwf  count
009C         00296 txbaudwait
009C 0BA7    00297         decfsz delay, F
009D 289C    00298         goto    txbaudwait
009E 3020    00299         movlw  baudconst
009F 00A7    00300         movwf  delay
00A0 0BA5    00301         decfsz count, F
00A1 28A6    00302         goto    SendNextBit
00A2 3009    00303         movlw  0x9
00A3 00A5    00304         movwf  count
00A4 1786    00305         bsf     tx ;send stop bit
00A5 0008    00306         return
00A6         00307 SendNextBit
00A6 0CA6    00308         rrf     txreg, F
00A7 1C03    00309         btfss  STATUS,C
00A8 28AB    00310         goto    Setlo
00A9 1786    00311         bsf     tx
00AA 289C    00312         goto    txbaudwait
00AB 1386    00313 Setlo   bcf     tx
00AC 289C    00314         goto    txbaudwait
           00315 ;_____
           00316

```

AN611

```
00317 ;*****
00318 ;*-----*
00319 ;*-      Generic Transmit Routine                                -*
00320 ;*-      Sends what is currently in the W register and accumulator ACCc -*
00321 ;*-----*
00322 ;*****
00AD      00323 Send
00AD 2095 00324      call    Transmit
00AE 2146 00325      call    delay1      ;delay between bytes
00AF 0856 00326      movf    ACCcHI,W      ;transmit high resistance byte
00B0 2095 00327      call    Transmit
00B1 2146 00328      call    delay1      ;delay between bytes
00B2 0857 00329      movf    ACCcMID,W     ;transmit mid resistance byte
00B3 2095 00330      call    Transmit
00B4 2146 00331      call    delay1      ;delay between bytes
00B5 0858 00332      movf    ACCcLO,W     ;transmit low resistance byte
00B6 2095 00333      call    Transmit
00B7 2146 00334      call    delay1      ;delay between bytes
00B8 0008 00335      return
00336 ;-----
00337
00338 ;*****
00339 ;*-----*
00340 ;*-      Interrupt Service Routines                                -*
00341 ;*-----*
00342 ;*****
00B9      00343 ServiceInterrupts
00B9 00A0 00344      movwf   W_TEMP          ;Pseudo push instructions
00BA 0E03 00345      swapf   STATUS,W
00BB 1283 00346      bcf     STATUS,RP0
00BC 00A1 00347      movwf   STATUS_TEMP
00348
00BD 0801 00349      movf    TMR0,W
00BE 00A3 00350      movwf   Ttemp
00BF 190B 00351      btfs   INTCON,T0IF      ;Service Timer0 overflow
00C0 20E5 00352      call   ServiceTimer
00C1 1B0C 00353      btfs   PIR1,CMIF      ;Stops Timer0, Records Value
00C2 20EC 00354      call   ServiceComparator
00C3 180B 00355      btfs   INTCON,RBIF    ;Service pushbutton switch
00C4 20CB 00356      call   ServiceKeystroke ;Starts a measurement
00357
00C5 1283 00358      bcf    STATUS,RP0
00C6 0E21 00359      swapf  STATUS_TEMP,W  ;Pseudo pop instructions
00C7 0083 00360      movwf  STATUS
00C8 0EA0 00361      swapf  W_TEMP,F
00C9 0E20 00362      swapf  W_TEMP,W
00363
00CA 0009 00364      retfie
00365 ;-----
00366
00367 ;*****
00368 ;*-----*
00369 ;*-      Borrowed from AN552, "Implementing Wake-up on Key Stroke"  -*
00370 ;*-      Author: Stan D'Souza                                        -*
00371 ;*-----*
00372 ;*****
00CB      00373 ServiceKeystroke
00CB 118B 00374      bcf    INTCON,RBIE    ;disable interrupt
00CC 0906 00375      comf   PORTB,W      ;read PORTB
00CD 100B 00376      bcf    INTCON,RBIF   ;clear interrupt flag
00CE 3940 00377      andlw  B'01000000'
00CF 1903 00378      btfs   STATUS,Z
00D0 28D6 00379      goto  NotSwitch
00D1 2143 00380      call   delay16      ;de-bounce switch for 16msec
00D2 0906 00381      comf   PORTB,W      ;read PORTB again
00D3 20D9 00382      call   KeyRelease   ;check for key release
```

```

00D4 1424    00383      bsf      flags,BEGIN
00D5 0008    00384      return
00385
00D6         00386 NotSwitch          ;detected other PORTB pin change
00D6 100B    00387      bcf      INTCON,RBIF      ;reset RBI interrupt
00D7 158B    00388      bsf      INTCON,RBIE
00D8 0008    00389      return
00390
00D9         00391 KeyRelease
00D9 2143    00392      call     delay16          ;debounce switch
00DA 0906    00393      comf     PORTB,W          ;read PORTB
00DB 100B    00394      bcf      INTCON,RBIF      ;clear flag
00DC 158B    00395      bsf      INTCON,RBIE      ;enable interrupt
00DD 3940    00396      andlw   B'01000000'
00DE 1903    00397      btfsc   STATUS,Z          ;key still pressed?
00DF 0008    00398      return          ;if no, then return
00E0 0063    00399      sleep           ;else, save power
00E1 118B    00400      bcf      INTCON,RBIE      ;disable interrupts
00E2 0906    00401      comf     PORTB,W          ;read PORTB
00E3 100B    00402      bcf      INTCON,RBIF      ;clear flag
00E4 28D9    00403      goto    KeyRelease       ;try again
00404 ; _____
00405
00406 ;*****
00407 ;*-----*
00408 ;*-      ISR to service a Timer0 overflow          -*
00409 ;*-----*
00410 ;*****
00E5         00411 ServiceTimer
00E5 0AC1    00412      incf     TimeMID,F        ;increment middle Time byte
00E6 1903    00413      btfsc   STATUS,Z          ;if middle overflows,
00E7 0AC2    00414      incf     TimeHI,F        ;increment high Time byte
00E8 1AC2    00415      btfsc   TimeHI,EMPTY     ;check if component is connected
00E9 15A4    00416      bsf      flags,F_ERROR    ;set error flag
00EA 110B    00417      bcf      INTCON,T0IF      ;clear TMR0 interrupt flag
00EB 0008    00418      return
00419 ; _____
00420
00421 ;*****
00422 ;*-----*
00423 ;*-      ISR to service a Comparator interrupt      -*
00424 ;*-----*
00425 ;*****
00EC         00426 ServiceComparator
00EC 1283    00427      bcf      STATUS,RP0       ;select bank 0
00ED 1E86    00428      btfss   PORTB,WHICH      ;detect which measurement, R or C?
00EE 28F2    00429      goto    capcomp
00EF 1F1F    00430      btfss   CMCON,C1OUT      ;detect if R ckt has interrupted
00F0 28F4    00431      goto    scstop
00F1 28F9    00432      goto    scend
00F2         00433 capcomp
00F2 1B9F    00434      btfsc   CMCON,C2OUT      ;detect if C ckt has interrupted
00F3 28F9    00435      goto    scend
00F4         00436 scstop
00F4 128B    00437      bcf      INTCON,T0IE      ;disable TMR0 interrupts
00F5 110B    00438      bcf      INTCON,T0IF
00F6 0823    00439      movf    Ttemp,W
00F7 00C0    00440      movwf   TimeLO
00F8 17A4    00441      bsf      flags,DONE       ;set DONE flag
00F9         00442 scend
00F9 130C    00443      bcf      PIR1,CMIF       ;clear comparator interrupt flag
00FA 0008    00444      return
00445 ; _____
00446
00447 ;*****
00448 ;*-----*

```

AN611

```
00449 ;*-      Turn Comparators and Vref On                      -*
00450 ;*-----*
00451 ;*****
00FB      00452 AnalogOn
00FB 1283 00453      bcf      STATUS,RP0      ;select bank 0
00FC 3002 00454      movlw    0x02          ;turn comparators on, mode 010
00FD 009F 00455      movwf   CMCON          ;4 inputs multiplexed to 2 comparators
00FE 1683 00456      bsf     STATUS,RP0      ;select bank 1
00FF 300F 00457      movlw    0x0F          ;make PORTA<3:0> all inputs
0100 0085 00458      movwf   TRISA
0101 179F 00459      bsf     VRCON,VREN
0102 1283 00460      bcf     STATUS,RP0      ;select bank 0
0103 2140 00461      call    delay20        ;20msec delay
0104 089F 00462      movf    CMCON,F          ;clear comparator mismatch condition
0105 130C 00463      bcf     PIR1,CMIF        ;clear comparator interrupt flag
0106 1683 00464      bsf     STATUS,RP0
0107 170C 00465      bsf     PIE1,CMIE        ;enable comparator interrupts
0108 1283 00466      bcf     STATUS,RP0
0109 170B 00467      bsf     INTCON,PEIE     ;enable peripheral interrupts
010A 11A4 00468      bcf     flags,F_ERROR
010B 0181 00469      clrf   TMR0           ;clear TMR0 counter
010C 0000 00470      nop
010D 0000 00471      nop
010E 110B 00472      bcf     INTCON,T0IF     ;clear TMR0 interrupt flag
010F 168B 00473      bsf     INTCON,T0IE     ;enable TMR0 interrupts
0110 0008 00474      return
00475 ;-----*
00476 ;*****
00477 ;*-----*
00478 ;*-----*
00479 ;*-      Turn Comparators and Vref Off                      -*
00480 ;*-----*
00481 ;*****
0111      00482 AnalogOff
0111 1283 00483      bcf     STATUS,RP0
0112 130B 00484      bcf     INTCON,PEIE
0113 3080 00485      movlw    0x80          ;reset PORTB value
0114 0086 00486      movwf   PORTB
0115 1683 00487      bsf     STATUS,RP0      ;select bank 1
0116 130C 00488      bcf     PIE1,CMIE        ;disable comparator interrupts
0117 0185 00489      clrf   TRISA          ;set PORTA pins to outputs, discharge RC ckt
0118 3060 00490      movlw    0x60          ;set PORTB 7,4-0 as outputs, 6,5 as inputs
0119 0086 00491      movwf   TRISB
011A 139F 00492      bcf     VRCON,VREN      ;disable Vref
011B 1283 00493      bcf     STATUS,RP0      ;select bank 0
011C 3007 00494      movlw    0x07
011D 009F 00495      movwf   CMCON          ;disable comparators
011E 2140 00496      call    delay20        ;20msec delay
011F 089F 00497      movf    CMCON,F          ;clear comparator mismatch condition
0120 130C 00498      bcf     PIR1,CMIF        ;clear comparator interrupt flag
0121 110B 00499      bcf     INTCON,T0IF     ;clear Timer0 interrupt flag
0122 213D 00500      call    vlong          ;long delay to allow capacitors to discharge
0123 213D 00501      call    vlong
0124 213D 00502      call    vlong
0125 0008 00503      return
00504 ;-----*
00505 ;*****
00506 ;*-----*
00507 ;*-----*
00508 ;*-      Swap Time to Accumulator a                          -*
00509 ;*-----*
00510 ;*****
0126      00511 SwapTtoA
0126 1283 00512      bcf     STATUS,RP0
0127 0842 00513      movf    TimeHI,W
0128 00D0 00514      movwf   ACCaHI
```



```

0129 0841    00515      movf    TimeMID,W
012A 00D1    00516      movwf   ACCaMID
012B 0840    00517      movf    TimeLO,W
012C 00D2    00518      movwf   ACCaLO
012D 01C2    00519      clrf    TimeHI
012E 01C1    00520      clrf    TimeMID
012F 01C0    00521      clrf    TimeLO
0130 0008    00522      return
00523 ; _____
00524
00525 ;*****
00526 ;*-----*
00527 ;*-      Transmit the Boot Message                      -*
00528 ;*-----*
00529 ;*****
0131 00530 BootMSG
0131 1283    00531      bcf     STATUS,RP0      ;select bank 0
0132 3002    00532 msg   movlw   HIGH Table     ;init the PCH for a table call
0133 008A    00533      movwf   PCLATH
0134 0828    00534      movf    offset,W        ;move table offset into W
0135 2200    00535      call   Table            ;get table value
0136 2095    00536      call   Transmit         ;transmit table value
0137 2146    00537      call   delay1           ;delay between bytes
0138 0BA8    00538      decfsz offset,F        ;check for end of table
0139 2932    00539      goto   msg
013A 3010    00540      movlw   0x10            ;reset table offset
013B 00A8    00541      movwf   offset
013C 0008    00542      return
00543 ; _____
00544
00545 ;*****
00546 ;*-----*
00547 ;*-      Delay Routines                                  -*
00548 ;*-----*
00549 ;*****
013D 30FF    00550 vlong  movlw   0xff          ;very long delay, approx 200msec
013E 00A9    00551      movwf   msb
013F 2948    00552      goto   d1
0140      00553 delay20          ;20 msec delay
0140 301A    00554      movlw   .26
0141 00A9    00555      movwf   msb
0142 2948    00556      goto   d1
0143      00557 delay16          ;16 msec delay
0143 3015    00558      movlw   .21
0144 00A9    00559      movwf   msb
0145 2948    00560      goto   d1
0146      00561 delay1          ;approx 750nsec delay
0146 3001    00562      movlw   .1
0147 00A9    00563      movwf   msb
0148 30FF    00564 d1     movlw   0xff
0149 00AA    00565      movwf   lsb
014A 0BAA    00566 d2     decfsz  lsb,F
014B 294A    00567      goto   d2
014C 0BA9    00568      decfsz  msb,F
014D 2948    00569      goto   d1
014E 0008    00570      return
00571 ; _____
00572
00573
0200      00574      org     0x200
00575
00576
00577 ;*****
00578 ;*-----*
00579 ;*-      Table for Boot Message                      -*
00580 ;*-----*

```

AN611

```
00581 ;*****
0200 00582 Table                                ;boot message "PICMETER Booted!"
0200 0782 00583      addwf   PCL, F                ;add W to PCL
0201 3400 00584      retlw   0
0202 3421 00585      retlw   \'!\'
0203 3464 00586      retlw   \'d\'
0204 3465 00587      retlw   \'e\'
0205 3474 00588      retlw   \'t\'
0206 346F 00589      retlw   \'o\'
0207 346F 00590      retlw   \'o\'
0208 3442 00591      retlw   \'B\'
0209 3420 00592      retlw   \' \'
020A 3452 00593      retlw   \'R\'
020B 3445 00594      retlw   \'E\'
020C 3454 00595      retlw   \'T\'
020D 3445 00596      retlw   \'E\'
020E 344D 00597      retlw   \'M\'
020F 3443 00598      retlw   \'C\'
0210 3449 00599      retlw   \'I\'
0211 3450 00600      retlw   \'P\'
00601 ;
00602
00603 ;*****
00604 ;*-----*
00605 ;*-      24-bit Addition                                -*
00606 ;*-
00607 ;*-      Uses ACCa and ACCb                            -*
00608 ;*-
00609 ;*-      ACCa + ACCb -> ACCb                            -*
00610 ;*-----*
00611 ;*****
0212 00612 Add24
0212 0852 00613      movf    ACCaLO,W
0213 07D5 00614      addwf   ACCbLO, F                ;add low bytes
0214 1803 00615      btfsc   STATUS,C                ;add in carry if necessary
0215 2A1D 00616      goto    A2
0216 0851 00617 A1    movf    ACCaMID,W
0217 07D4 00618      addwf   ACCbMID, F                ;add mid bytes
0218 1803 00619      btfsc   STATUS,C                ;add in carry if necessary
0219 0AD3 00620      incf    ACCbHI, F
021A 0850 00621      movf    ACCaHI,W
021B 07D3 00622      addwf   ACCbHI, F                ;add high bytes
021C 3400 00623      retlw   0
021D 0AD4 00624 A2    incf    ACCbMID, F
021E 1903 00625      btfsc   STATUS,Z
021F 0AD3 00626      incf    ACCbHI, F
0220 2A16 00627      goto    A1
00628 ;
00629
00630 ;*****
00631 ;*-----*
00632 ;*-      Subtraction ( 24 - 24 -> 24 )                    -*
00633 ;*-
00634 ;*-      Uses ACCa, ACCb, ACCd                            -*
00635 ;*-
00636 ;*-      ACCa -> ACCd,
00637 ;*-      2's complement ACCa,
00638 ;*-      call Add24 ( ACCa + ACCb -> ACCb ),
00639 ;*-      ACCd -> ACCa
00640 ;*-----*
00641 ;*****
0221 00642 Sub24
0221 0850 00643      movf    ACCaHI,W                ;Transfer ACCa to ACCd
0222 00D9 00644      movwf   ACCdHI
0223 0851 00645      movf    ACCaMID,W
0224 00DA 00646      movwf   ACCdMID
```

```

0225 0852    00647    movf    ACCaLO,W
0226 00DB    00648    movwf   ACCdLO
0227 2275    00649    call   compA           ;2's complement ACCa
0228 2212    00650    call   Add24           ;Add ACCa to ACCb
0229 0859    00651    movf   ACCdHI,W       ;Transfer ACCd to ACCa
022A 00D0    00652    movwf  ACCaHI
022B 085A    00653    movf   ACCdMID,W
022C 00D1    00654    movwf  ACCaMID
022D 085B    00655    movf   ACCdLO,W
022E 00D2    00656    movwf  ACCaLO
022F 3400    00657    retlw  0
00658 ; _____
00659
00660 ;*****
00661 ;*-----*
00662 ;*-      Multiply ( 24 X 24 -> 56 )           -*
00663 ;*-                                           -*
00664 ;*-      Uses ACCa, ACCb, ACCc, ACCd         -*
00665 ;*-                                           -*
00666 ;*-      ACCa * ACCb -> ACCb,ACCc 56-bit output -*
00667 ;*-      with ACCb (ACCbHI,ACCbMID,ACCbLO) with 24 msb's and -*
00668 ;*-      ACCc (ACCcHI,ACCcMID,ACCcLO) with 24 lsb's    -*
00669 ;*-----*
00670 ;*****
0230 00671 Mpy24
0230 223F    00672    call   Msetup
0231 OCD9    00673 mloop  rrf   ACCdHI, F       ;rotate d right
0232 OCDA    00674    rrf   ACCdMID, F
0233 OCDB    00675    rrf   ACCdLO, F
0234 1803    00676    btfsc STATUS,C         ;need to add?
0235 2212    00677    call   Add24
0236 OCD3    00678    rrf   ACCbHI, F
0237 OCD4    00679    rrf   ACCbMID, F
0238 OCD5    00680    rrf   ACCbLO, F
0239 OCD6    00681    rrf   ACCcHI, F
023A OCD7    00682    rrf   ACCcMID, F
023B OCD8    00683    rrf   ACCcLO, F
023C 0BDC    00684    decfsz temp, F         ;loop until all bits checked
023D 2A31    00685    goto  mloop
023E 3400    00686    retlw  0
00687
023F 00688 Msetup
023F 3018    00689    movlw  0x18           ;for 24 bit shifts
0240 00DC    00690    movwf  temp
0241 0853    00691    movf   ACCbHI,W       ;move ACCb to ACCd
0242 00D9    00692    movwf  ACCdHI
0243 0854    00693    movf   ACCbMID,W
0244 00DA    00694    movwf  ACCdMID
0245 0855    00695    movf   ACCbLO,W
0246 00DB    00696    movwf  ACCdLO
0247 01D3    00697    clrf  ACCbHI
0248 01D4    00698    clrf  ACCbMID
0249 01D5    00699    clrf  ACCbLO
024A 3400    00700    retlw  0
00701 ; _____
00702
00703 ;*****
00704 ;*-----*
00705 ;*-      Division ( 56 / 24 -> 24 )           -*
00706 ;*-                                           -*
00707 ;*-      Uses ACCa, ACCb, ACCc, ACCd         -*
00708 ;*-                                           -*
00709 ;*-      56-bit dividend in ACCb,ACCc ( ACCb has msb's and ACCc has lsb's) -*
00710 ;*-      24-bit divisor in ACCa              -*
00711 ;*-      quotient is stored in ACCc         -*
00712 ;*-      remainder is stored in ACCb       -*

```

AN611

```

00713 ;*-----*
00714 ;*****
024B      00715 Div24
024B 2272      00716      call      Dsetup
00717
024C 1003      00718 dloop   bcf      STATUS,C
024D ODD8      00719      rlf      ACCcLO, F      ;Rotate dividend left 1 bit position
024E ODD7      00720      rlf      ACCcMID, F
024F ODD6      00721      rlf      ACCcHI, F
0250 ODD5      00722      rlf      ACCbLO, F
0251 ODD4      00723      rlf      ACCbMID, F
0252 ODD3      00724      rlf      ACCbHI, F
00725
0253 1803      00726      btfsz   STATUS,C      ;invert carry and exclusive or with the
0254 2A58      00727      goto    clear         ;msb of the divisor then move this bit
0255 1FD0      00728      btfsz   ACCaHI,msb_bit ;into the lsb of the dividend
0256 0AD8      00729      incf    ACCcLO, F
0257 2A5A      00730      goto    cont
0258 1BD0      00731 clear   btfsz   ACCaHI,msb_bit
0259 0AD8      00732      incf    ACCcLO, F
00733
025A 1858      00734 cont    btfsz   ACCcLO,lsb_bit ;check the lsb of the dividend
025B 2A5E      00735      goto    minus
025C 2212      00736      call    Add24         ;if = 0, then add divisor to upper 24 bits
025D 2A5F      00737      goto    check         ;of dividend
025E 2221      00738 minus  call    Sub24         ;if = 1, then subtract divisor from upper
00739      ;24 bits of dividend
00740
025F 0BDC      00741 check  decfsz  temp,f      ;do 24 times
0260 2A4C      00742      goto    dloop
00743
0261 1003      00744      bcf     STATUS,C
0262 ODD8      00745      rlf     ACCcLO, F      ;shift lower 24 bits of dividend 1 bit
0263 ODD7      00746      rlf     ACCcMID, F      ;position left
0264 ODD6      00747      rlf     ACCcHI, F
0265 1BD3      00748      btfsz   ACCbHI,msb_bit ;exclusive or the inverse of the msb of the
0266 2A6A      00749      goto    w1            ;dividend with the msb of the divisor
0267 1FD0      00750      btfsz   ACCaHI,msb_bit ;store in the lsb of the dividend
0268 0AD8      00751      incf    ACCcLO, F
0269 2A6C      00752      goto    wzd
026A 1BD0      00753 w1      btfsz   ACCaHI,msb_bit
026B 0AD8      00754      incf    ACCcLO, F
026C 1FD3      00755 wzd     btfsz   ACCbHI,msb_bit ;if the msb of the remainder is set and
026D 2A71      00756      goto    wend
026E 1BD0      00757      btfsz   ACCaHI,msb_bit ;the msb of the divisor is not
026F 2A71      00758      goto    wend
0270 2212      00759      call    Add24         ;add the divisor to the remainder to correct
00760      ;for zero partial remainder
00761
0271 3400      00762 wend    retlw   0      ;quotient in 24 lsb's of dividend
00763      ;remainder in 24 msb's of dividend
00764
0272      00765 Dsetup
0272 3018      00766      movlw   0x18         ;loop 24 times
0273 00DC      00767      movwf   temp
00768
0274 3400      00769      retlw   0
00770 ; _____
00771
00772 ;*****
00773 ;*-----*
00774 ;*      2's Complement      -*
00775 ;*      -*
00776 ;*      Uses ACCa      -*
00777 ;*      -*
00778 ;*      Performs 2's complement conversion on ACCa      -*

```

```

00779 ;*-----*
00780 ;*****
0275      00781 compA
0275 09D2 00782      comf   ACCaLO, F           ;invert all bits in accumulator a
0276 09D1 00783      comf   ACCaMID, F
0277 09D0 00784      comf   ACCaHI, F
0278 0AD2 00785      incf   ACCaLO, F           ;add one to accumulator a
0279 1903 00786      btfsc  STATUS,Z
027A 0AD1 00787      incf   ACCaMID, F
027B 1903 00788      btfsc  STATUS,Z
027C 0AD0 00789      incf   ACCaHI, F
027D 3400 00790      retlw  0
00791 ;_____
00792
00793      END

```

PICMETER Firmware for PIC16C622
MEMORY USAGE MAP ('X' = Used, '-' = Unused)

```

0000 : X---X----- XXXXXXXXXXXXXXXX XXXXXXXXXXXXXXXX XXXXXXXXXXXXXXXX
0040 : XXXXXXXXXXXXXXXX XXXXXXXXXXXXXXXX XXXXXXXXXXXXXXXX XXXXXXXXXXXXXXXX
0080 : XXXXXXXXXXXXXXXX XXXXXXXXXXXXXXXX XXXXXXXXXXXXXXXX XXXXXXXXXXXXXXXX
00C0 : XXXXXXXXXXXXXXXX XXXXXXXXXXXXXXXX XXXXXXXXXXXXXXXX XXXXXXXXXXXXXXXX
0100 : XXXXXXXXXXXXXXXX XXXXXXXXXXXXXXXX XXXXXXXXXXXXXXXX XXXXXXXXXXXXXXXX
0140 : XXXXXXXXXXXXXXXX- -----
0200 : XXXXXXXXXXXXXXXX XXXXXXXXXXXXXXXX XXXXXXXXXXXXXXXX XXXXXXXXXXXXXXXX
0240 : XXXXXXXXXXXXXXXX XXXXXXXXXXXXXXXX XXXXXXXXXXXXXXXX XXXXXXXXXXXXXXXX--
2000 : -----X----- -----

```

All other memory blocks unused.

Program Memory Words Used: 447
Program Memory Words Free: 1601

Errors : 0
Warnings : 0 reported, 0 suppressed
Messages : 0 reported, 15 suppressed

APPENDIX B: VISUAL BASIC PROGRAM

PICMTR.FRM

```
Sub Form_Load ()
    'Initialize the program
    Image1.Height = 600
    Image1.Width = 2700
    Frame1.Caption = "PICMETER Power Off"
    Label1.Caption = ""
    Label2.Caption = ""

    'Initialize Comm Port 1
    Comml.RThreshold = 1
    Comml.Handshaking = 0
    Comml.Settings = "9600,n,8,1"
    Comml.CommPort = 2
    Comml.PortOpen = True

    'Initialize the global variable First%
    First% = 0
End Sub

Sub Form_Unload (Cancel As Integer)
    'Unload PICMETER
    Comml.RTSEnable = False
    Comml.DTREnable = False
    Comml.PortOpen = False
    Unload PICMETER
End Sub

Sub Comml_OnComm ()
    Dim Value As Double
    Dim High As Double
    Dim Medium As Double
    Dim Low As Double

    'Received a character
    If Comml.CommEvent = 2 Then
        If First% = 0 Then
            If Comml.InBufferCount = 16 Then
                Label1.FontSize = 10
                InString$ = Comml.Input
                If InString$ = "PICMETER Booted!" Then
                    Frame1.Caption = "PICMETER Booted!"
                End If
                First% = 1
                Comml.InputLen = 4
            End If
        Else
            If Comml.InBufferCount >= 4 Then
                InString$ = Comml.Input
                If Left$(InString$, 1) = "R" Then
                    Frame1.Caption = "Resistance"
                    Label2.FontName = "Symbol"
                    Label2.Caption = "KW"
                    Label1.FontSize = 24
                ElseIf Left$(InString$, 1) = "C" Then
                    Frame1.Caption = "Capacitance"
                    Label2.FontName = "MS Sans Serif"
                    Label2.Caption = "nF"
                    Label1.FontSize = 24
                ElseIf Left$(InString$, 1) = "E" Then
                    Frame1.Caption = "Error Detected"
                    Label2.Caption = ""
                ElseIf Left$(InString$, 1) = "S" Then
                    Frame1.Caption = "Measuring Component"
                    Label2.Caption = ""
                Else
                    Frame1.Caption = "Error Detected"
                    Label2.Caption = ""
                End If
            End If
        End If
    End If
End Sub
```

```
        If Framel.Caption = "Error Detected" Then
            Label1.Caption = ""
        ElseIf Framel.Caption = "Measuring Component" Then
            Label1.Caption = ""
        Else
            High = 65536# * Asc(Mid$(InString$, 2, 1))
            Medium = 256# * Asc(Mid$(InString$, 3, 1))
            Low = Asc(Mid$(InString$, 4, 1))
            Label1.Caption = Format$((High + Medium + Low) / 1000, "###0.0")
        End If
    End If
End If
End Sub

Sub Check3D1_Click (Value As Integer)
    'Control Power to the PICMETER
    If Check3D1.Value = False Then
        Comml.InputLen = 0
        Label1.Caption = ""
        Label2.Caption = ""
        Comml.RTSEnable = False
        Comml.DTREnable = False
        Framel.Caption = "PICMETER Power Off"
        InString$ = Comml.Input
    Else
        Framel.Caption = ""
        First% = 0
        Comml.InputLen = 0
        InString$ = Comml.Input
        Comml.RTSEnable = True
        Comml.DTREnable = True
    End If
End Sub

Sub menExitTop_Click ()
    'Unload PICMETER
    Unload PICMETER
End Sub

Sub Option1_Click ()
    'Open COM1 for communications
    If Option1.Value = True Then
        If Comml.CommPort = 2 Then
            Comml.PortOpen = False
            Comml.CommPort = 1
            Comml.PortOpen = True
        End If
    End If
End Sub

Sub Option2_Click ()
    'Open COM2 for communications
    If Option2.Value = True Then
        If Comml.CommPort = 1 Then
            Comml.PortOpen = False
            Comml.CommPort = 2
            Comml.PortOpen = True
        End If
    End If
End Sub
```

PICMETER.BAS

```
Global I%
Global First%
```

AN611

APPENDIX C: PICMETER PCB LAYOUT

Boards Manufactured by: Southwest Circuits
Contact: Perry Groves
3760 E. 43rd Place
Tucson, AZ 85713
1-520-745-8515

The following artwork is not printed to scale:

Component Side

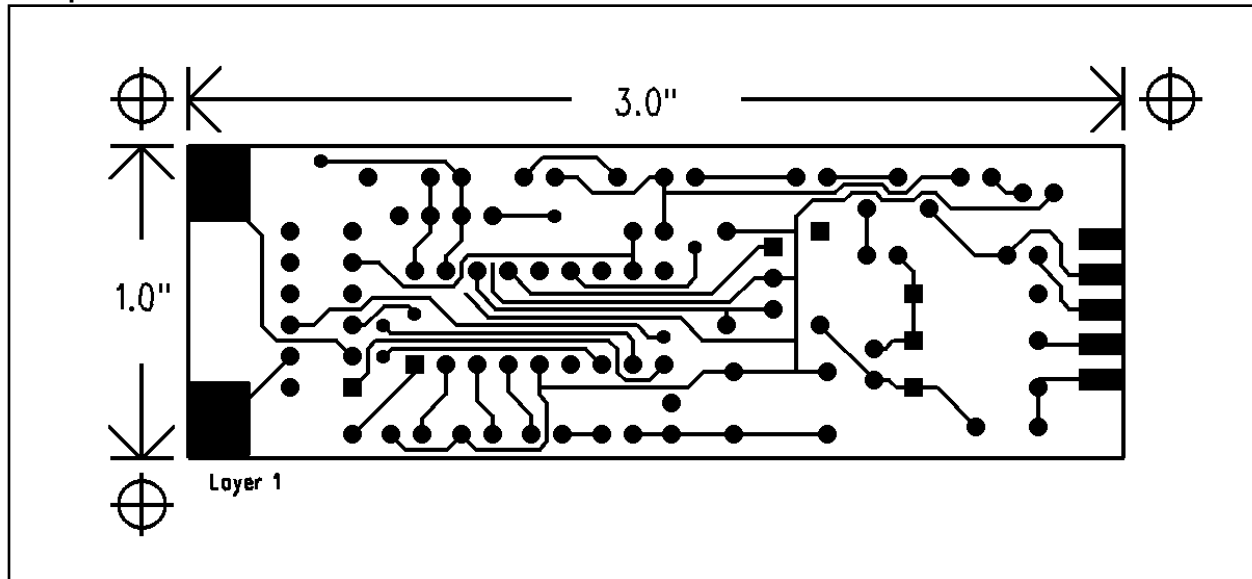

Solder Side

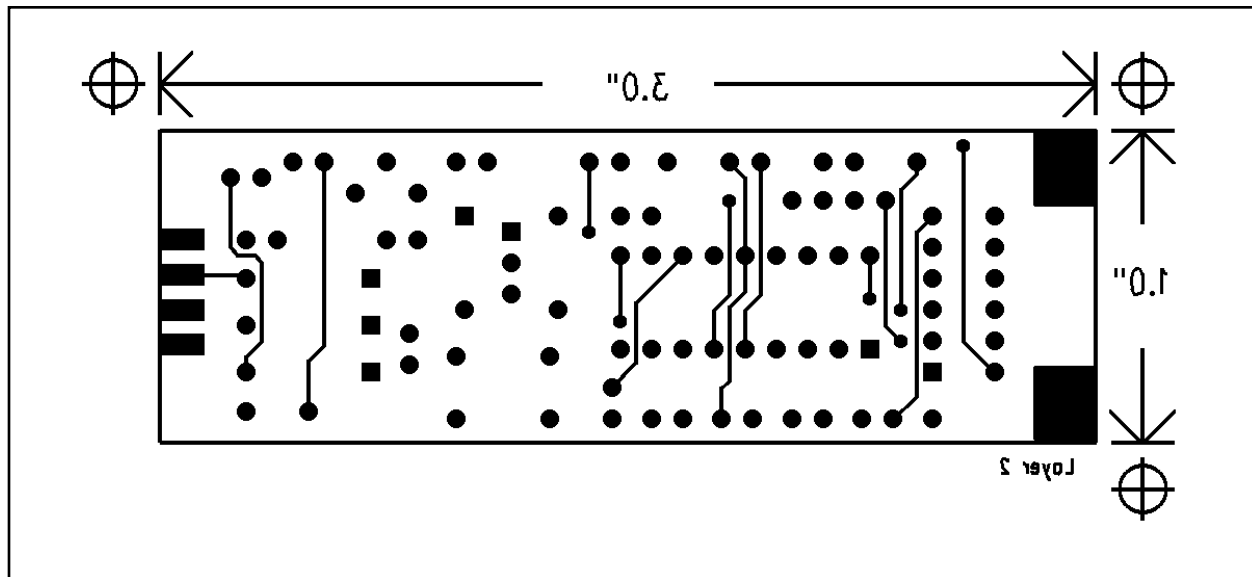

Component Side Silkscreen

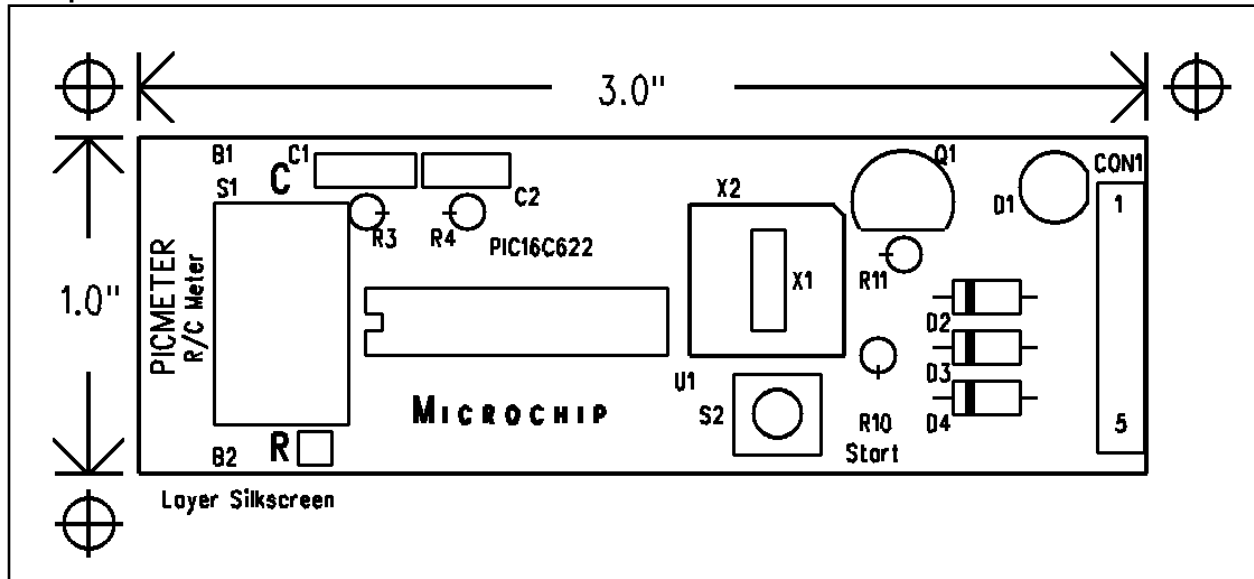

Solder Side Silkscreen

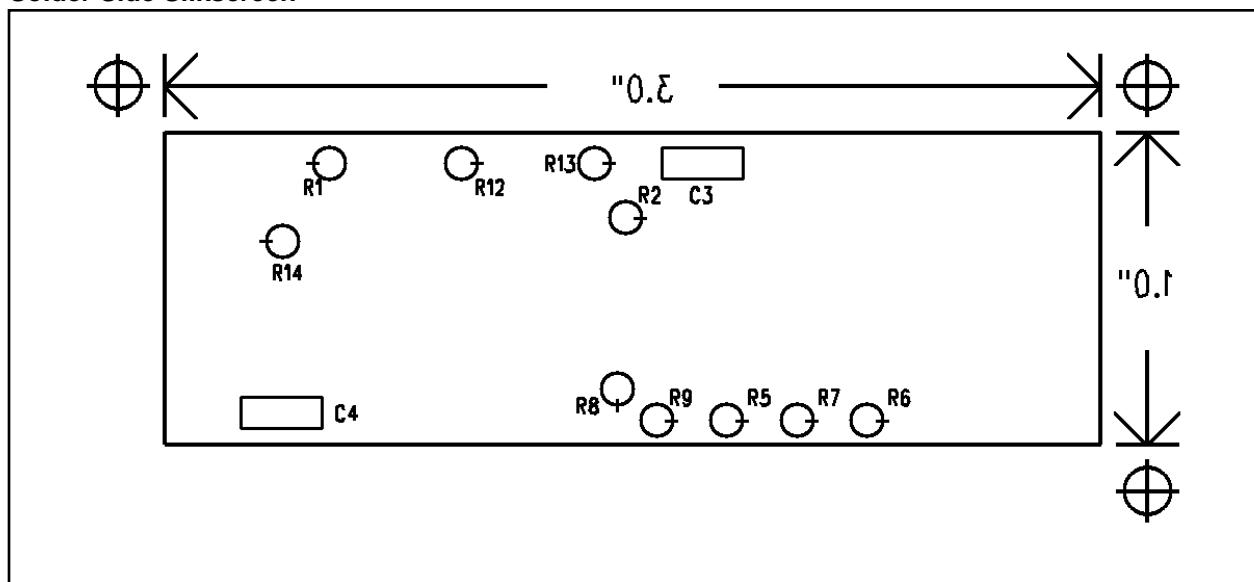

AN611

Manufacturing Drawing

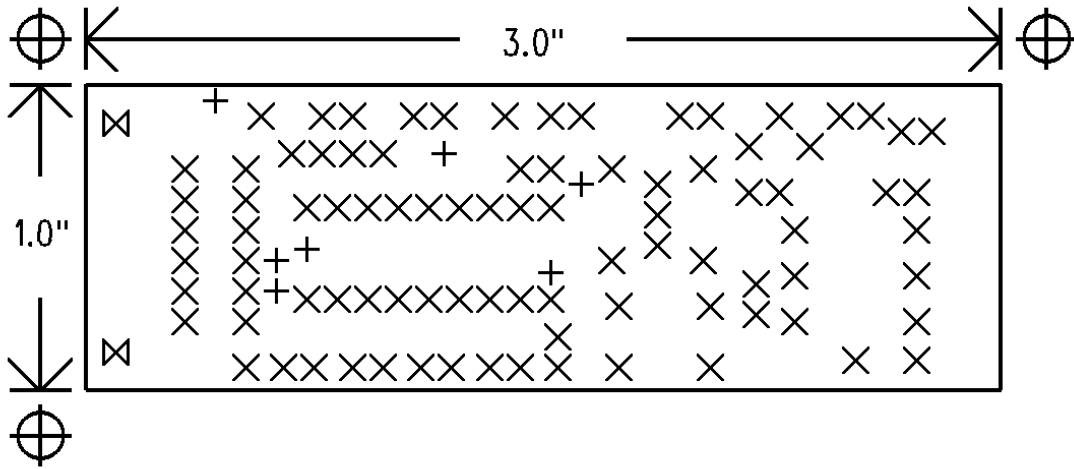

SIZE	QTY	SYM
18	7	+
37	89	X
95	2	⊠



WORLDWIDE SALES AND SERVICE

AMERICAS

Corporate Office

Microchip Technology Inc.
2355 West Chandler Blvd.
Chandler, AZ 85224-6199
Tel: 480-786-7200 Fax: 480-786-7277
Technical Support: 480-786-7627
Web Address: <http://www.microchip.com>

Atlanta

Microchip Technology Inc.
500 Sugar Mill Road, Suite 200B
Atlanta, GA 30350
Tel: 770-640-0034 Fax: 770-640-0307

Boston

Microchip Technology Inc.
5 Mount Royal Avenue
Marlborough, MA 01752
Tel: 508-480-9990 Fax: 508-480-8575

Chicago

Microchip Technology Inc.
333 Pierce Road, Suite 180
Itasca, IL 60143
Tel: 630-285-0071 Fax: 630-285-0075

Dallas

Microchip Technology Inc.
4570 Westgrove Drive, Suite 160
Addison, TX 75248
Tel: 972-818-7423 Fax: 972-818-2924

Dayton

Microchip Technology Inc.
Two Prestige Place, Suite 150
Miamisburg, OH 45342
Tel: 937-291-1654 Fax: 937-291-9175

Detroit

Microchip Technology Inc.
Tri-Atria Office Building
32255 Northwestern Highway, Suite 190
Farmington Hills, MI 48334
Tel: 248-538-2250 Fax: 248-538-2260

Los Angeles

Microchip Technology Inc.
18201 Von Karman, Suite 1090
Irvine, CA 92612
Tel: 949-263-1888 Fax: 949-263-1338

New York

Microchip Technology Inc.
150 Motor Parkway, Suite 202
Hauppauge, NY 11788
Tel: 631-273-5305 Fax: 631-273-5335

San Jose

Microchip Technology Inc.
2107 North First Street, Suite 590
San Jose, CA 95131
Tel: 408-436-7950 Fax: 408-436-7955

AMERICAS (continued)

Toronto

Microchip Technology Inc.
5925 Airport Road, Suite 200
Mississauga, Ontario L4V 1W1, Canada
Tel: 905-405-6279 Fax: 905-405-6253

ASIA/PACIFIC

Hong Kong

Microchip Asia Pacific
Unit 2101, Tower 2
Metroplaza
223 Hing Fong Road
Kwai Fong, N.T., Hong Kong
Tel: 852-2-401-1200 Fax: 852-2-401-3431

Beijing

Microchip Technology, Beijing
Unit 915, 6 Chaoyangmen Bei Dajie
Dong Erhuan Road, Dongcheng District
New China Hong Kong Manhattan Building
Beijing 100027 PRC
Tel: 86-10-85282100 Fax: 86-10-85282104

India

Microchip Technology Inc.
India Liaison Office
No. 6, Legacy, Convent Road
Bangalore 560 025, India
Tel: 91-80-229-0061 Fax: 91-80-229-0062

Japan

Microchip Technology Intl. Inc.
Benex S-1 6F
3-18-20, Shinyokohama
Kohoku-Ku, Yokohama-shi
Kanagawa 222-0033 Japan
Tel: 81-45-471-6166 Fax: 81-45-471-6122

Korea

Microchip Technology Korea
168-1, Youngbo Bldg. 3 Floor
Samsung-Dong, Kangnam-Ku
Seoul, Korea
Tel: 82-2-554-7200 Fax: 82-2-558-5934

Shanghai

Microchip Technology
RM 406 Shanghai Golden Bridge Bldg.
2077 Yan'an Road West, Hong Qiao District
Shanghai, PRC 200335
Tel: 86-21-6275-5700 Fax: 86 21-6275-5060

ASIA/PACIFIC (continued)

Singapore

Microchip Technology Singapore Pte Ltd.
200 Middle Road
#07-02 Prime Centre
Singapore 188980
Tel: 65-334-8870 Fax: 65-334-8850

Taiwan, R.O.C

Microchip Technology Taiwan
10F-1C 207
Tung Hua North Road
Taipei, Taiwan, ROC
Tel: 886-2-2717-7175 Fax: 886-2-2545-0139

EUROPE

United Kingdom

Arizona Microchip Technology Ltd.
505 Eskdale Road
Wokingham
Berkshire, England RG41 5TU
Tel: 44 118 921 5858 Fax: 44-118 921-5835

Denmark

Microchip Technology Denmark ApS
Regus Business Centre
Lautrup hof 1-3
Ballerup DK-2750 Denmark
Tel: 45 4420 9895 Fax: 45 4420 9910

France

Arizona Microchip Technology SARL
Parc d'Activite du Moulin de Massy
43 Rue du Saule Trapu
Batiment A - 1er Etage
91300 Massy, France
Tel: 33-1-69-53-63-20 Fax: 33-1-69-30-90-79

Germany

Arizona Microchip Technology GmbH
Gustav-Heinemann-Ring 125
D-81739 München, Germany
Tel: 49-89-627-144 0 Fax: 49-89-627-144-44

Italy

Arizona Microchip Technology SRL
Centro Direzionale Colleoni
Palazzo Taurus 1 V. Le Colleoni 1
20041 Agrate Brianza
Milan, Italy
Tel: 39-039-65791-1 Fax: 39-039-6899883

11/15/99

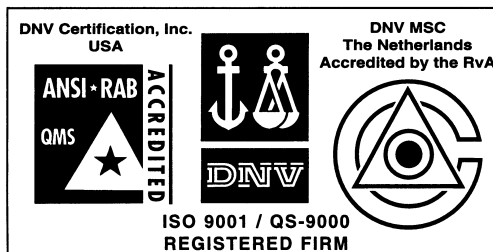

Microchip received QS-9000 quality system certification for its worldwide headquarters, design and water fabrication facilities in Chandler and Tempe, Arizona in July 1999. The Company's quality system processes and procedures are QS-9000 compliant for its PICmicro® 8-bit MCUs, KEELOC® code hopping devices, Serial EEPROMs and microperipheral products. In addition, Microchip's quality system for the design and manufacture of development systems is ISO 9001 certified.

All rights reserved. © 1999 Microchip Technology Incorporated. Printed in the USA. 11/99 Printed on recycled paper.

Information contained in this publication regarding device applications and the like is intended for suggestion only and may be superseded by updates. No representation or warranty is given and no liability is assumed by Microchip Technology Incorporated with respect to the accuracy or use of such information, or infringement of patents or other intellectual property rights arising from such use or otherwise. Use of Microchip's products as critical components in life support systems is not authorized except with express written approval by Microchip. No licenses are conveyed, implicitly or otherwise, under any intellectual property rights. The Microchip logo and name are registered trademarks of Microchip Technology Inc. in the U.S.A. and other countries. All rights reserved. All other trademarks mentioned herein are the property of their respective companies.