

How to Implement ICSP™ Using PIC16CXXX OTP MCUs

*Author: Rodger Richey
Microchip Technology Inc.*

INTRODUCTION

In-Circuit Serial Programming (ICSP™) is a great way to reduce your inventory overhead and time-to-market for your product. By assembling your product with a blank Microchip microcontroller (MCU), you can stock one design. When an order has been placed, these units can be programmed with the latest revision of firmware, tested, and shipped in a very short time. This method also reduces scrapped inventory due to old firmware revisions. This type of manufacturing system can also facilitate quick turnarounds on custom orders for your product.

Most people would think to use ICSP with PICmicro™ OTP MCUs only on an assembly line where the device is programmed once. However, there is a method by which an OTP device can be programmed several times depending on the size of the firmware. This method, explained later, provides a way to field upgrade your firmware in a way similar to EEPROM- or Flash-based devices.

HOW DOES ICSP WORK?

Now that ICSP appeals to you, what steps do you take to implement it in your application? There are three main components of an ICSP system: Application Circuit, Programmer and Programming Environment.

Application Circuit

The application circuit must be designed to allow all the programming signals to be directly connected to the PICmicro. Figure 1 shows a typical circuit that is a starting point for when designing with ICSP. The application must compensate for the following issues:

1. Isolation of the $\overline{\text{MCLR/VPP}}$ pin from the rest of the circuit.
2. Isolation of pins RB6 and RB7 from the rest of the circuit.
3. Capacitance on each of the V_{DD} , $\overline{\text{MCLR/VPP}}$, RB6, and RB7 pins.
4. Minimum and maximum operating voltage for V_{DD} .
5. PICmicro Oscillator.
6. Interface to the programmer.

The $\overline{\text{MCLR/VPP}}$ pin is normally connected to an RC circuit. The pull-up resistor is tied to V_{DD} and a capacitor is tied to ground. This circuit can affect the operation of ICSP depending on the size of the capacitor. It is, therefore, recommended that the circuit in Figure 1 be used when an RC is connected to $\overline{\text{MCLR/VPP}}$. The diode should be a Schottky-type device. Another issue with $\overline{\text{MCLR/VPP}}$ is that when the PICmicro device is programmed, this pin is driven to approximately 13V and also to ground. Therefore, the application circuit must be isolated from this voltage provided by the programmer.

FIGURE 1: TYPICAL APPLICATION CIRCUIT

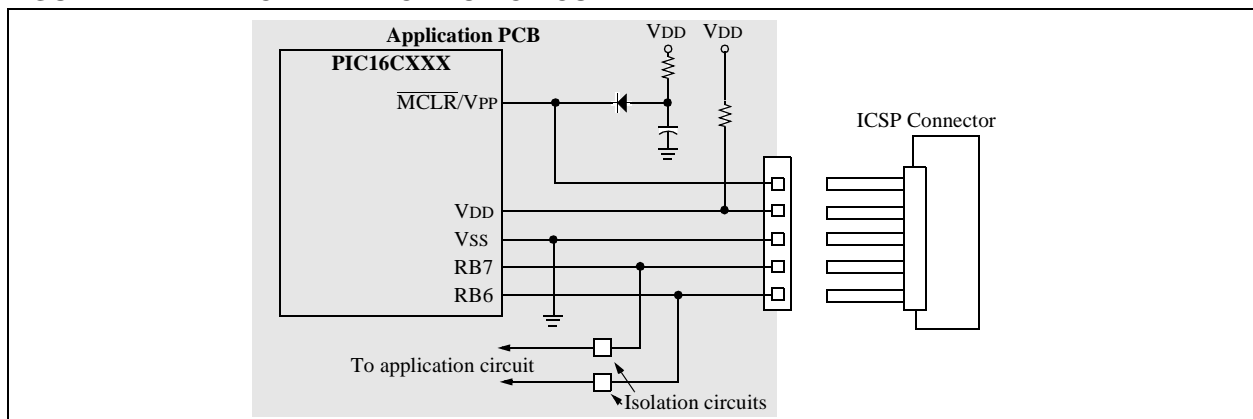

PRO MATE and PICSTART are registered trademarks and PICmicro and ICSP are trademarks of Microchip Technology Inc.

Pins RB6 and RB7 are used by the PICmicro for serial programming. RB6 is the clock line and RB7 is the data line. RB6 is driven by the programmer. RB7 is a bi-directional pin that is driven by the programmer when programming, and driven by the PICmicro when verifying. These pins must be isolated from the rest of the application circuit so as not to affect the signals during programming. You must take into consideration the output impedance of the programmer when isolating RB6 and RB7 from the rest of the circuit. This isolation circuit must account for RB6 being an input on the PICmicro, and for RB7 being bi-directional (can be driven by both the PICmicro and the programmer). For instance, PRO MATE® II has an output impedance of 1k Ω . If the design permits, these pins should not be used by the application. This is not the case with most applications so it is recommended that the designer evaluate whether these signals need to be buffered. As a designer, you must consider what type of circuitry is connected to RB6 and RB7 and then make a decision on how to isolate these pins. Figure 1 does not show any circuitry to isolate RB6 and RB7 on the application circuit because this is very application dependent.

The total capacitance on the programming pins affects the rise rates of these signals as they are driven out of the programmer. Typical circuits use several hundred microfarads of capacitance on VDD which helps to dampen noise and ripple. However, this capacitance requires a fairly strong driver in the programmer to meet the rise rate timings for VDD. Most programmers are designed to simply program the PICmicro itself and don't have strong enough drivers to power the application circuit. One solution is to use a driver board between the programmer and the application circuit. The driver board requires a separate power supply that is capable of driving the VPP and VDD pins with the correct rise rates and should also provide enough current to power the application circuit. RB6 and RB7 are not buffered on this schematic but may require buffering depending upon the application. A sample driver board schematic is shown in Appendix A.

Note: The driver board design MUST be tested in the user's application to determine the effects of the application circuit on the programming signals timing. Changes may be required if the application places a significant load on VDD, VPP, RB6 OR RB7.

The Microchip programming specification states that the device should be programmed at 5V. Special considerations must be made if your application circuit operates at 3V only. These considerations may include totally isolating the PICmicro during programming. The other issue is that the device must be verified at the minimum and maximum voltages at which the application circuit will be operating. For instance, a battery

operated system may operate from three 1.5V cells giving an operating voltage range of 2.7V to 4.5V. The programmer must program the device at 5V and must verify the program memory contents at both 2.7V and 4.5V to ensure that proper programming margins have been achieved. This ensures the PICmicro option over the voltage range of the system.

This final issue deals with the oscillator circuit on the application board. The voltage on MCLR/VPP must rise to the specified program mode entry voltage before the device executes any code. The crystal modes available on the PICmicro are not affected by this issue because the Oscillator Start-up Timer waits for 1024 oscillations before any code is executed. However, RC oscillators do not require any startup time and, therefore, the Oscillator Startup Timer is not used. The programmer must drive MCLR/VPP to the program mode entry voltage before the RC oscillator toggles four times. If the RC oscillator toggles four or more times, the program counter will be incremented to some value X. Now when the device enters programming mode, the program counter will not be zero and the programmer will start programming your code at an offset of X. There are several alternatives that can compensate for a slow rise rate on MCLR/VPP. The first method would be to not populate the R, program the device, and then insert the R. The other method would be to have the programming interface drive the OSC1 pin of the PICmicro to ground while programming. This will prevent any oscillations from occurring during programming.

Now all that is left is how to connect the application circuit to the programmer. This depends a lot on the programming environment and will be discussed in that section.

Programmer

The second consideration is the programmer. PIC16CXXX MCUs only use serial programming and therefore all programmers supporting these devices will support ICSP. One issue with the programmer is the drive capability. As discussed before, it must be able to provide the specified rise rates on the ICSP signals and also provide enough current to power the application circuit. Appendix A shows an example driver board. This driver schematic does not show any buffer circuitry for RB6 and RB7. It is recommended that an evaluation be performed to determine if buffering is required. Another issue with the programmer is what VDD levels are used to verify the memory contents of the PICmicro. For instance, the PRO MATE II verifies program memory at the minimum and maximum VDD levels for the specified device and is therefore considered a production quality programmer. On the other hand, the PICSTART® Plus only verifies at 5V and is for prototyping use only. The Microchip programming specifications state that the program memory contents should be verified at both the minimum and maximum VDD levels that the application circuit will be operating. This implies that the application circuit must be able to handle the varying VDD voltages.

How to Implement ICSP™ Using PIC16CXXX OTP MCUs

There are also several third party programmers that are available. You should select a programmer based on the features it has and how it fits into your programming environment. The *Microchip Development Systems Ordering Guide* (DS30177) provides detailed information on all our development tools. The *Microchip Third Party Guide* (DS00104) provides information on all of our third party tool developers. Please consult these two references when selecting a programmer. Many options exist including serial or parallel PC host connection, stand-alone operation, and single or gang programmers. Some of the third party developers include Advanced Transdata Corporation, BP Microsystems, Data I/O, Emulation Technology and Logical Devices.

Programming Environment

The programming environment will affect the type of programmer used, the programmer cable length, and the application circuit interface. Some programmers are well suited for a manual assembly line while others are desirable for an automated assembly line. You may want to choose a gang programmer to program multiple systems at a time.

The physical distance between the programmer and the application circuit affects the load capacitance on each of the programming signals. This will directly affect the drive strength needed to provide the correct signal rise rates and current. This programming cable must also be as short as possible and properly terminated and shielded, or the programming signals may be corrupted by ringing or noise.

Finally, the application circuit interface to the programmer depends on the size constraints of the application circuit itself and the assembly line. A simple header can be used to interface the application circuit to the programmer. This might be more desirable for a manual assembly line where a technician plugs the programmer cable into the board. A different method is the use of spring loaded test pins (commonly referred to as pogo pins). The application circuit has pads on the board for each of the programming signals. Then there is a fixture that has pogo pins in the same configuration as the pads on the board. The application circuit or fixture is moved into position such that the pogo pins come into contact with the board. This method might be more suitable for an automated assembly line.

After taking into consideration the issues with the application circuit, the programmer, and the programming environment, anyone can build a high quality, reliable manufacturing line based on ICSP.

Other Benefits

ICSP provides other benefits, such as calibration and serialization. If program memory permits, it would be cheaper and more reliable to store calibration constants in program memory instead of using an external serial EEPROM. For example, your system has a thermistor which can vary from one system to another. Storing some calibration information in a table format allows the microcontroller to compensate in software for external component tolerances. System cost can be reduced without affecting the required performance of the system by using software calibration techniques. But how does this relate to ICSP? The PICmicro has already been programmed with firmware that performs a calibration cycle. The calibration data is transferred to a calibration fixture. When all calibration data has been transferred, the fixture places the PICmicro in programming mode and programs the PICmicro with the calibration data. Application note *AN656, In-Circuit Serial Programming of Calibration Parameters Using a PICmicro Microcontroller*, shows exactly how to implement this type of calibration data programming.

The other benefit of ICSP is serialization. Each individual system can be programmed with a unique or random serial number. One such application of a unique serial number would be for security systems. A typical system might use DIP switches to set the serial number. Instead, this number can be burned into program memory, thus reducing the overall system cost and lowering the risk of tampering.

Field Programming of PICmicro OTP MCUs

An OTP device is not normally capable of being reprogrammed, but the PICmicro architecture gives you this flexibility provided the size of your firmware is at least half that of the desired device and the device is not code protected. If your target device does not have enough program memory, Microchip provides a wide spectrum of devices from 0.5K to 8K program memory with the same set of peripheral features that will help meet the criteria.

The PIC16CXXX microcontrollers have two vectors, reset and interrupt, at locations 0x0000 and 0x0004. When the PICmicro encounters a reset or interrupt condition, the code located at one of these two locations in program memory is executed. The first listing of Example 1 shows the code that is first programmed into the PICmicro. The second listing of Example 1 shows the code that is programmed into the PICmicro for the second time.

EXAMPLE 1: PROGRAMMING CYCLE LISTING FILES

First Program Cycle				Second Program Cycle			
Prog Mem	Opcode	Assembly Instruction		Prog Mem	Opcode	Assembly Instruction	
0000	2808	goto Main	;Main loop	0000	0000	nop	
0001	3FFF	<blank>	;at 0x0008	0001	2860	goto Main	;Main now
0002	3FFF	<blank>		0002	3FFF	<blank>	;at 0x0060
0003	3FFF	<blank>		0003	3FFF	<blank>	
0004	2848	goto ISR	;ISR at	0004	0000	nop	
0005	3FFF	<blank>	;0x0048	0005	28A8	goto ISR	;ISR now at
0006	3FFF	<blank>		0006	3FFF	<blank>	;0x00A8
0007	3FFF	<blank>		0007	3FFF	<blank>	
0008	1683	bsf STATUS,RP0		0008	1683	bsf STATUS,RP0	
0009	3007	movlw 0x07		0009	3007	movlw 0x07	
000A	009F	movwf ADCON1		000A	009F	movwf ADCON1	
.				.			
.				.			
.				.			
0048	1C0C	btss PIR1,RBIF		0048	1C0C	btss PIR1,RBIF	
0049	284E	goto EndISR		0049	284E	goto EndISR	
004A	1806	btsc PORTB,0		004A	1806	btsc PORTB,0	
.				.			
.				.			
.				.			
0060	3FFF	<blank>		0060	1683	bsf STATUS,RP0	
0061	3FFF	<blank>		0061	3005	movlw 0x05	
0062	3FFF	<blank>		0062	009F	movwf ADCON1	
.				.			
.				.			
.				.			
00A8	3FFF	<blank>		00A8	1C0C	btss PIR1,RBIF	
00A9	3FFF	<blank>		00A9	28AE	goto EndISR	
00AA	3FFF	<blank>		00AA	1806	btsc PORTB,0	
.				.			
.				.			
.				.			

How to Implement ICSP™ Using PIC16CXXX OTP MCUs

The example shows that to program the PICmicro a second time the memory location 0x0000, originally `goto Main` (0x2808), is reprogrammed to all 0's which happens to be a `nop` instruction. This location cannot be reprogrammed to the new opcode (0x2860) because the bits that are 0's cannot be reprogrammed to 1's, only bits that are 1's can be reprogrammed to 0's. The next memory location 0x0001 was originally blank (all 1's) and now becomes a `goto Main` (0x2860). When a reset condition occurs, the PICmicro executes the instruction at location 0x0000 which is the `nop`, a completely benign instruction, and then executes the `goto Main` to start the execution of code. The example also shows that all program memory locations after 0x005A are blank in the original program so that the second time the PICmicro is programmed, the revised code can be programmed at these locations. The same descriptions can be given for the interrupt vector at location 0x0004.

This method changes slightly for PICmicros with >2K words of program memory. Each of the `goto Main` and `goto ISR` instructions are replaced by the following code segments due to paging on devices with >2K words of program memory.

```
movlw <page>           movlw <page>
movwf PCLATH           movwf PCLATH
goto Main              goto ISR
```

Now your one time programmable PICmicro is exhibiting more EEPROM- or Flash-like qualities.

CONCLUSION

Microchip Technology Inc. is committed to supporting your ICSP needs by providing you with our many years of experience and expertise in developing ICSP solutions. Anyone can create a reliable ICSP programming station by coupling our background with some forethought to the circuit design and programmer selection issues previously mentioned. Your local Microchip representative is available to answer any questions you have about the requirements for ICSP.

APPENDIX A: SAMPLE DRIVER BOARD SCHEMATIC

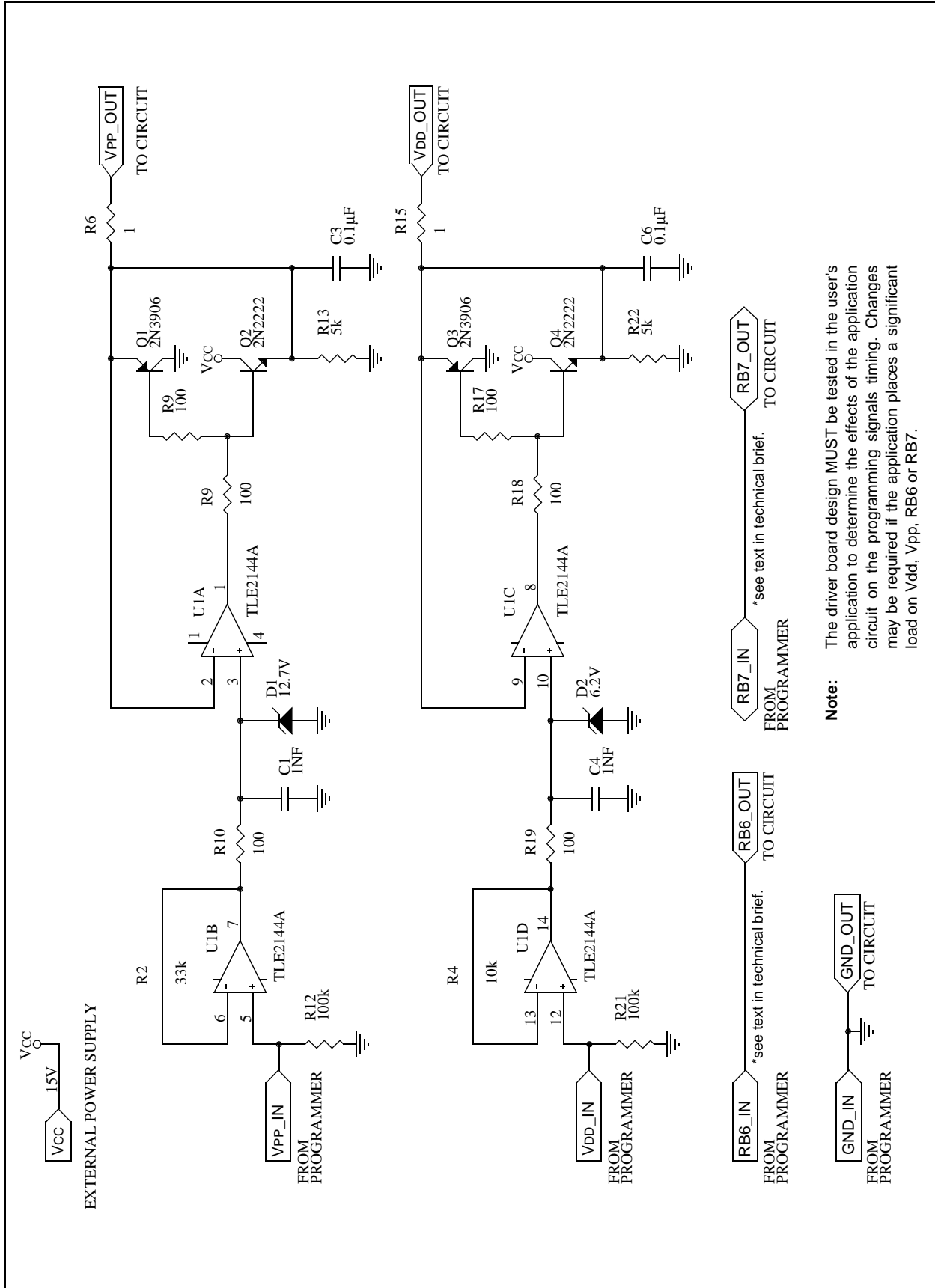

How to Implement ICSP™ Using PIC16CXXX OTP MCUs

NOTES:



WORLDWIDE SALES AND SERVICE

AMERICAS

Corporate Office

Microchip Technology Inc.
2355 West Chandler Blvd.
Chandler, AZ 85224-6199
Tel: 480-786-7200 Fax: 480-786-7277
Technical Support: 480-786-7627
Web Address: <http://www.microchip.com>

Atlanta

Microchip Technology Inc.
500 Sugar Mill Road, Suite 200B
Atlanta, GA 30350
Tel: 770-640-0034 Fax: 770-640-0307

Boston

Microchip Technology Inc.
5 Mount Royal Avenue
Marlborough, MA 01752
Tel: 508-480-9990 Fax: 508-480-8575

Chicago

Microchip Technology Inc.
333 Pierce Road, Suite 180
Itasca, IL 60143
Tel: 630-285-0071 Fax: 630-285-0075

Dallas

Microchip Technology Inc.
4570 Westgrove Drive, Suite 160
Addison, TX 75248
Tel: 972-818-7423 Fax: 972-818-2924

Dayton

Microchip Technology Inc.
Two Prestige Place, Suite 150
Miamisburg, OH 45342
Tel: 937-291-1654 Fax: 937-291-9175

Detroit

Microchip Technology Inc.
Tri-Atria Office Building
32255 Northwestern Highway, Suite 190
Farmington Hills, MI 48334
Tel: 248-538-2250 Fax: 248-538-2260

Los Angeles

Microchip Technology Inc.
18201 Von Karman, Suite 1090
Irvine, CA 92612
Tel: 949-263-1888 Fax: 949-263-1338

New York

Microchip Technology Inc.
150 Motor Parkway, Suite 202
Hauppauge, NY 11788
Tel: 631-273-5305 Fax: 631-273-5335

San Jose

Microchip Technology Inc.
2107 North First Street, Suite 590
San Jose, CA 95131
Tel: 408-436-7950 Fax: 408-436-7955

AMERICAS (continued)

Toronto

Microchip Technology Inc.
5925 Airport Road, Suite 200
Mississauga, Ontario L4V 1W1, Canada
Tel: 905-405-6279 Fax: 905-405-6253

ASIA/PACIFIC

Beijing

Microchip Technology, Beijing
Unit 915, 6 Chaoyangmen Bei Dajie
Dong Erhuan Road, Dongcheng District
New China Hong Kong Manhattan Building
Beijing 100027 PRC
Tel: 86-10-85282100 Fax: 86-10-85282104

Hong Kong

Microchip Asia Pacific
Unit 2101, Tower 2
Metroplaza
223 Hing Fong Road
Kwai Fong, N.T., Hong Kong
Tel: 852-2-401-1200 Fax: 852-2-401-3431

India

Microchip Technology Inc.
India Liaison Office
No. 6, Legacy, Convent Road
Bangalore 560 025, India
Tel: 91-80-229-0061 Fax: 91-80-229-0062

Japan

Microchip Technology Intl. Inc.
Benex S-1 6F
3-18-20, Shinyokohama
Kohoku-Ku, Yokohama-shi
Kanagawa 222-0033 Japan
Tel: 81-45-471-6166 Fax: 81-45-471-6122

Korea

Microchip Technology Korea
168-1, Youngbo Bldg. 3 Floor
Samsung-Dong, Kangnam-Ku
Seoul, Korea
Tel: 82-2-554-7200 Fax: 82-2-558-5934

Shanghai

Microchip Technology
Unit B701, Far East International Plaza,
No. 317, Xianxia Road
Shanghai, 200051 P.R.C.
Tel: 86-21-6275-5700 Fax: 86-21-6275-5060

ASIA/PACIFIC (continued)

Singapore

Microchip Technology Singapore Pte Ltd.
200 Middle Road
#07-02 Prime Centre
Singapore 188980
Tel: 65-334-8870 Fax: 65-334-8850

Taiwan, R.O.C

Microchip Technology Taiwan
10F-1C 207
Tung Hua North Road
Taipei, Taiwan, ROC
Tel: 886-2-2717-7175 Fax: 886-2-2545-0139

EUROPE

Denmark

Microchip Technology Denmark ApS
Regus Business Centre
Lautrup høj 1-3
Ballerup DK-2750 Denmark
Tel: 45 4420 9895 Fax: 45 4420 9910

France

Arizona Microchip Technology SARL
Parc d'Activite du Moulin de Massy
43 Rue du Saule Trapu
Batiment A - 1er Etage
91300 Massy, France
Tel: 33-1-69-53-63-20 Fax: 33-1-69-30-90-79

Germany

Arizona Microchip Technology GmbH
Gustav-Heinemann-Ring 125
D-81739 München, Germany
Tel: 49-89-627-144 0 Fax: 49-89-627-144-44

Italy

Arizona Microchip Technology SRL
Centro Direzionale Colleoni
Palazzo Taurus 1 V. Le Colleoni 1
20041 Agrate Brianza
Milan, Italy
Tel: 39-039-65791-1 Fax: 39-039-6899883

United Kingdom

Arizona Microchip Technology Ltd.
505 Eskdale Road
Winnersh Triangle
Wokingham
Berkshire, England RG41 5TU
Tel: 44 118 921 5858 Fax: 44-118 921-5835

01/21/00

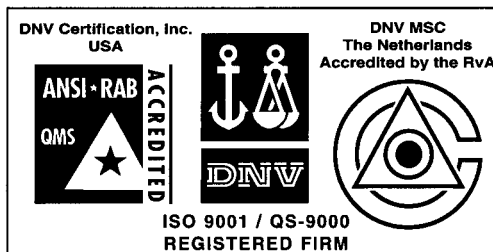

Microchip received QS-9000 quality system certification for its worldwide headquarters, design and wafer fabrication facilities in Chandler and Tempe, Arizona in July 1999. The Company's quality system processes and procedures are QS-9000 compliant for its PICmicro® 8-bit MCUs, KEELoc® code hopping devices, Serial EEPROMs and microperipheral products. In addition, Microchip's quality system for the design and manufacture of development systems is ISO 9001 certified.

All rights reserved. © 2000 Microchip Technology Incorporated. Printed in the USA. 2/00 Printed on recycled paper.

Information contained in this publication regarding device applications and the like is intended through suggestion only and may be superseded by updates. It is your responsibility to ensure that your application meets with your specifications. No representation or warranty is given and no liability is assumed by Microchip Technology Incorporated with respect to the accuracy or use of such information, or infringement of patents or other intellectual property rights arising from such use or otherwise. Use of Microchip's products as critical components in life support systems is not authorized except with express written approval by Microchip. No licenses are conveyed, implicitly or otherwise, except as maybe explicitly expressed herein, under any intellectual property rights. The Microchip logo and name are registered trademarks of Microchip Technology Inc. in the U.S.A. and other countries. All rights reserved. All other trademarks mentioned herein are the property of their respective companies.